



JOLLY MEC

PADDY 6 kW

PADDY 8 kW

**INSTALLATION, USE AND
MAINTENANCE MANUAL**

To be kept by the purchaser



PADDY

Pellet operated air heating stove

Dear Customer,

thank you for having chosen to heat and save with a Jolly Mec product. Please carefully read and keep this sheet before using the equipment.

This sheet provides necessary information and suggestions on how to correctly install, use, clean and maintain the product. Knowing and observing these instructions will allow you to fully and safely enjoy the potential your equipment can offer you.

TABLE OF CONTENTS

CHAP.01	PREMISES.....	4
01.1	WARNINGS.....	4
01.2	SYMBOLOLOGY.....	5
01.3	APPLIED STANDARDS.....	5
01.4	USE AND STORING OF THE INSTALLATION AND MAINTENANCE MANUAL.....	6
01.5	MANUFACTURER LIABILITY AND WARRANTY CONDITIONS.....	6
CHAP.02	ACCIDENT PREVENTION / SAFETY REGULATIONS.....	7
02.1	GENERAL CONSIDERATIONS.....	7
02.2	SAFETY REGULATIONS FOR ROUTINE MAINTENANCE AND USE.....	7
02.3	SAFETY REGULATIONS FOR EXTRAORDINARY MAINTENANCE AND INSTALLATION.....	8
02.4	EQUIPMENT FOR OPERATORS AND MAINTENANCE PERSONNEL.....	9
02.5	RESIDUAL RISKS.....	9
CHAP.03	HANDLING AND TRANSPORT.....	10
03.1	RECEIVING GOODS.....	10
03.2	LIFTING AND TRANSPORT.....	10
CHAP.04	ECOLOGICAL REGULATIONS.....	11
04.1	DISPOSAL OF THE MACHINE.....	11
CHAP.05	DESCRIPTION.....	13
05.1	PRODUCT PRESENTATION.....	13
05.2	PRODUCT IDENTIFICATION.....	14
CHAP.06	TECHNICAL DATA.....	15
06.1	HOMOLOGATION.....	15
06.2	RECOMMENDED FUELS.....	16
06.3	COMPONENTS.....	17
06.4	DIMENSIONS.....	18
CHAP.07	POSITIONING AND CONNECTIONS FOR THE INSTALLER.....	19
07.1	SETTING UP OF EXTERNAL AIR INTAKES AND ELECTRIC CURRENT.....	19
07.2	FLUE OR FUME EXHAUST SYSTEM.....	20
07.3	INSTALLATION ROOM VENTILATION.....	21
07.4	ASSEMBLY SEQUENCE.....	22
07.5	ELECTRICAL CONNECTIONS.....	22
07.6	CONTROL UNIT ELECTRICAL WIRING DIAGRAM.....	24
07.7	EXAMPLE OF AIR DUCTING IN THE VARIOUS ROOMS.....	25
CHAP.08	USE AND MAINTENANCE FOR THE USER.....	26
08.1	APPLIANCE OPERATIONS.....	26
08.2	CONTROL UNIT.....	26
08.3	APPLIANCE START AND USE.....	27
08.4	SAFETY THERMOSTAT WITH MANUAL RESET.....	28
08.5	TIPS FOR THE USER.....	29
08.6	ORDINARY MAINTENANCE (by the costumer).....	30
08.7	SCHEDULED PREVENTIVE MAINTENANCE (To be done by a specialised Technical Service Center).....	34
CHAP.09	FAULT DIAGNOSIS AND TROUBLESHOOTING.....	36
09.1	PROBLEMS.....	36
CHAP.10	ANNEXES.....	37
10.1	COMMISSION REGULATION (EU) 2015/1185.....	37

CHAP.01 PREMISES

01.1 WARNINGS

- *Familiarity and compliance with the instructions given in this manual will ensure quick installation and correct use of the appliance.*
- *Read the manual attentively before commencing installation, and be certain to follow the directions it contains, otherwise the warranty could be invalidated and the performance and safety of the appliance jeopardized.*
- *The installation manual is an integral part of the product and must be given to the user.*
- *It must be kept in a safe place and consulted carefully, as all of the warnings provide important information on safety during installation, use and maintenance.*
- *Incorrect installation of the appliance could cause damage and injury to people or animals, for which the manufacture cannot not be held liable.*
- *Installation shall be performed by qualified operators in accordance with the regulations in force in the Country of installation.*
- *The manufacturer declines any contractual or non-contractual liability for damages caused by errors in installation or use of the appliance or failure to follow the instructions contained in this manual.*
- *All rights on the reproduction of this technical manual are owned by Jolly Mec Caminetti S.p.A.*
- *The descriptions and illustrations provided in the following publication are not binding.*
- *Jolly Mec Caminetti S.p.A reserves the right to make any modifications that may be deemed appropriate.*
- *This manual cannot be given to third parties for perusal without the written permission of Jolly Mec Caminetti S.p.A*
- *The technical directions for installation contained in this manual should be considered as basic requirements. Regulations in some countries may be more restrictive; in this instance, comply fully with the regulations prevailing in the country of installation (**all laws and local bylaws must be observed when installing and using the appliance, including those referring to national and European standards**).*
- *Never use the appliance as an incinerator, or in way other than that for which it was designed. Any other use is deemed improper and therefore dangerous.*
- *Do not use fuels that are not recommended under penalty of cancellation of the warranty.*
- *When the appliance is running, the glass and other visible parts reach extremely hot temperatures to the touch; handle with extreme care to avoid burns.*
- *At the first ignition you may encounter bad smells and/or smoke due to the first heating of the paint. During this phase, you have to air the room where the product is installed and not stay there until the smells and/or smoke have completely disappeared.*
- *The boiler body is made of steel. The advantage of steel is the fast diffusion of the produced heat after a very short time from lightning. Steel undergoes temperature changes and consequently expands and contracts, this can give rise to temporary ticking and / or temporary noisy expansion.*
- *Do not place the appliance in direct contact with combustible materials.*
- *Do not make any unauthorised modification to the appliance. Any unauthorised modification will automatically invalidate the warranty and release the manufacture from all liability.*
- *Use only original spare parts recommended by the manufacturer. Original spare parts are available through retailers, specialised Tecnical Service Centers, or directly at the head office of Jolly Mec Caminetti S.p.A.*
- *Acceptance of the machine by the user must be “total”, including the sound level of operation, comparable to an electrical appliance. Complaints for characteristics not indicated in this manual shall not be accepted.*

01.2 SYMBOLOGY

In this manual, points of considerable importance are marked with the following symbology:



INSTRUCTION: Instructions regarding the correct use of the appliance.



WARNING: This point is particularly important.



DANGER: An important point regarding behaviour for preventing injury and damage to materials is expressed.

01.3 APPLIED STANDARDS

All JOLLY MEC products are constructed according to the following directives:

- **EU 305/2011** European construction products regulation.
- **2006/42/CE** Machines.
- **2014/30/UE** Electromagnetic compatibility (EMC).
- **2014/35/UE** Low voltage (LVD) - electrical safety.
- **2011/65/EU (RoHS2)** Restriction of the use of certain hazardous substances in electrical and electronic equipment
- **2014/53/UE** Radio Equipment
- **2018/68/UE** Pressure Equipment (PED)

And in compliance with the standards:

- **CEI EN 61000-3-2** Electromagnetic compatibility (EMC) - Limits - Limits for harmonic current emissions (equipment input current ≤ 16 A per phase).
- **CEI EN 61000-3-3** Electromagnetic compatibility (EMC) - Limits. Limitation of voltage changes, voltage fluctuations and flicker in public low-voltage supply systems, for equipment with rated current ≤ 16 A per phase and not subject to conditional connection.
- **EN 55014-1** Electromagnetic compatibility. - Requirements for household appliances, electric tools and similar apparatus - Emission
- **EN 55014-2** Electromagnetic compatibility – Requirements for household appliances, electric tools and similar apparatus - Immunity. Product family standard.
- **EN 60335-1** Safety of household electrical appliances and similar products. - General safety regulations
- **EN 60335-2-102** Safety of household electrical appliances and similar products. - Special regulations for appliances fitted with gas, diesel or solid fuel burners and electrical connections.
- **EN 62233** Measurement methods for electromagnetic fields of electrical appliances for home use and similar goods regarding human exposure.
- **EN 50581** Technical Documentation For The Assessment Of Electrical And Electronic Products With Respect To The Restriction Of Hazardous Substance
- **EN 7129** Domestic and similar gas systems powered by the distribution mains.
- **UNI 10412-2** Hot water heating system - Safety requirements - Specific requirements for systems with domestic type heating devices powered by solid fuel with built-in stove, with total fire power not over 35 kW.
- **UNI 10683** Heat generators operating with wood or other solid bio fuels - Installation requirements
- **UNI EN 303-5** Heating boilers. - Heating boilers for solid fuels, manually and automatically stoked, nominal heat output of up to 500 kW - Terminology, requirements, testing and marking.
- **UNI EN 1443** Fireplaces - General requisites
- **UNI EN 1856-1** Chimneys - Requirements for metal chimneys - System chimney products.
- **UNI EN 1856-2** Chimneys. Requirements for metal chimneys - Metal flue liners and connecting flue pipes.
- **UNI EN 13229** Insert appliances including open fires fired by solid fuels - Requirements and test methods
- **UNI EN 13240** Roomheaters fired by solid fuel - Requirements and test methods
- **UNI EN 13384** Fireplaces - Thermal calculations and dynamic fluid.
- **UNI EN 14785** Residential space heating appliances fired by wood pellets - Requirements and test methods
- **UNI EN ISO 12100** Machine safety.

01.4 USE AND STORING OF THE INSTALLATION AND MAINTENANCE MANUAL

- **Recipients of the manual**

The use and installation manual is addressed to users responsible for the installation, operation and maintenance of the stove; particular attention must be given the parts of the manual concerning safety.

If the product is subsequently resold, the user is requested to hand over this sheet and to inform the manufacturer of the name of the new owner, so that the latter may receive any updates issued.

- **Scope of the manual**

The manual contains information on the correct use of the product in accordance with the purposes for which it was designed and built. It also provides information about loads, commissioning, repair and maintenance of the stove in conformance with the limits set down by the manufacturer.

- **Conservation of the manual**

The installation and maintenance manual is an integral part of the product and must be conserved up to the time when the stove is dismantled. It must be kept in a protected, dry place out of direct sunlight and near the product so that it is always readily available for consultation.

Should the manual get damaged, the user must request a copy from the retailer where he purchased the appliance. When requesting assistance, always make reference to the MODEL, LOT and SERIAL NUMBER indicated on the label shown in **CHAP.05.2 - PRODUCT IDENTIFICATION**.

- **Updating the manual**

The installation and maintenance manual reflects the status of the technology at the time the product was marketed. The manufacturer reserves the right to make modifications to the product, and consequently the relative manual, without any obligation to update previous editions.

01.5 MANUFACTURER LIABILITY AND WARRANTY CONDITIONS

Upon the delivery of this manual, Jolly Mec S.p.A. cannot be held liable, whether civil or criminal, for accidents due to partial or total non-compliance with the specifications herein contained.

The manufacturer is especially held harmless from any liability in the following cases:

- Improper use of the product
- Use not intended by specific national regulations
- Incorrect installation
- Faults in the electrical connections, the connections of the fume exhaust system and/or the comburent air ducting system e and in plumbing connections
- Failure to carry out maintenance as prescribed in this manual
- Unauthorised modifications or operations
- Use of replacement parts that are non-original or not specific to the model
- Total or partial failure to follow the instructions
- Exceptional events (e.g.: breakages due to natural or accidental events as lightning, short circuits etc.)
- Damage caused by electrical power cuts, sudden fluctuation of supply voltage, electromagnetic fields
- Use of fuel with characteristics other than those recommended in this manual

In the above cases the warranty is void.

Please refer to Annex **SM082** for details on the warranty conditions and compiling the relative certificate.



NOTE





In the event of a malfunction or intervention request by a specialised Technical Service Center, the user must be able to demonstrate the use of fuel with the characteristics required by this manual. The Manufacturer disclaims all liability concerning anomalies or malfunctions caused by use of FUEL which does not comply with the recommended requirements.

CHAP.02 ACCIDENT PREVENTION / SAFETY REGULATIONS

02.1 GENERAL CONSIDERATIONS

- The manual refers to essential aspects of the directives, regulations and dispositions on using the machine, summarising its most significant points.
- General legal regulations and mandatory rules regarding injury prevention and environmental protection must be observed. These obligations also include regulations regarding the use of personal protective equipment.
- For all work to be done on the system, the following dispositions and regulations in force must be observed regarding accident prevention, following the indications.
- 
 - Before using the system the first time, the user must have read and understood the instruction manual perfectly and this chapter in particular.
 - The user must also make sure that the machine is always in good condition as regards its safety requirements.
- 
 - During maintenance and inspection activities, wear the protective garments specified in following **CHAP.02.4 - EQUIPMENT FOR OPERATORS AND MAINTENANCE PERSONNEL**. Cleaning and maintenance activities may only be performed with the equipment cold and preferably disconnected from the power mains or with the main switch in the "O" position.
 - Danger warnings and signals in the form of plates, labels and markings must not be removed or made unidentifiable. If they are worn or broken, they must be replaced.
- 
 - Modifications, additions or transformations must not be made on the machine and its components without the manufacturer's authorisation. This is valid first and foremost for installation and regulation of the installed safety devices. Failure to comply with this warning relieves the Manufacturer of all and any responsibility.
 - Make sure, before starting up every time and after carrying out maintenance, that dismantled parts have been repositioned correctly and in particular all the protection devices that impede access to the machine.

02.2 SAFETY REGULATIONS FOR ROUTINE MAINTENANCE AND USE

- 
 - The user and/or owner of the product is required, in accordance with the laws in force, to assign the installation and maintenance to qualified and specialised operators, and acknowledge the risks and hazards should they fail to observe this requirement.
 - Children of at least 8 years old, people with reduced physical, sensory or mental capabilities, or lacking the experience or the needed knowledge can use the device only under surveillance or having been instructed on the device safe use and on the understanding of the deriving dangers. Children are not allowed to play with the device. Cleaning and maintenance are meant to be performed by the user and not by unsupervised children.
 - The settings and programming of the product must only be performed by adults who have received suitable and specific training. Errors or incorrect settings can create hazardous conditions and trigger malfunctions with relative consequences for persons and things.
 - Before any cleaning and/or routine or extraordinary maintenance on the machine, disconnect it from all energy sources; in particular, turn the electrical power switch to "O".
 - Prior to installation, the user and installer are obliged to check that the mains electrical supply to which the machine will be connected, corresponds to the voltage on the identification plate (see **CHAP.05.2 - PRODUCT IDENTIFICATION**), and that it is equipped with all suitable safety devices to classify the electrical system as compliant with applicable safety standards. If this is not the case, contact a Qualified Technician to adapt the system to required standards.
 - Upstream from the machine (at the user's expense) on the electrical power supply line, a bipolar switch must be installed that is able to intercept all the current phases (see **CHAP.06 - TECHNICAL DATA**).
 - The irradiation area includes the area between the opening of the hearth and up to 0,9 metre of space frontally as well as laterally. No inflammable object must be left in this area (such as: inflammable liquids, fire-starting products or firewood, drapes, wooden decorations, rugs, etc.).
 - Do not use the stove to dry clothes, it could overheat and cause an outbreak of fire.
- 
 - **ATTENTION - BEWARE OF BURNS**, most of the outer surfaces of the stove are very hot, door handle, glass, metal sides, majolica or metal top, fume exhaust pipe etc. Never touch the stove with naked hands when it is running; always use heat protection gloves, such as those supplied with the stove, when handling all parts.
 - Before doing any internal cleaning or maintenance, you must wait until the machine reaches the ambient temperature.
 - If the stove is in alarm status due to a malfunction, do not attempt to restart it before finding out what has caused the heat generator to shut down.
 - Never wash the internal parts of the combustion chamber with water.

- In alarm status for failed start up, do not try to restart the appliance until the firebox has been thoroughly cleaned.
- The appliance must always be started up with the firebox empty, without pellets and without unburned fuel from previous use.
- Do not attempt to ignite the fuel with inflammable liquids or solids; the stove must ignite automatically via the electrical components installed onboard.
- Do not load pellets manually into the firebox before or whilst the appliance is running.
- Keep the ventilation grids in the area the appliance is installed in clean conditions.
- Never load any fuel other than pellets into the stove storage hopper. Corn, nuts or other combustible materials must not be used as fuel for the appliance.
- Check and periodically clean the fume exhaust pipe, from the appliance to the flue (Union).
- It is strictly prohibited to start up the product with the combustion chamber door open or allow it to run with the glass broken.
- In case of need and if any operating problems persist, the user should contact the specialised Technical Assistance Center.
- **Never try to start the device using ethyl alcohol or other flammable liquids.**



02.3 SAFETY REGULATIONS FOR EXTRAORDINARY MAINTENANCE AND INSTALLATION



- The user and/or owner of the product is required, in accordance with the laws in force, to assign the installation and maintenance to qualified and specialised operators, and acknowledge the risks and hazards should they fail to observe this requirement.
- The installation of the heat generator and the relative combustion product exhaustion system, the electrical connections, the commissioning and extraordinary maintenance services **MUST** always be performed by qualified and licensed professional staff.
- The product must be installed in accordance with the laws and standards in force in the State, Region or Area in which the machine is installed.
- Installation in bedrooms, rooms with a volume below 15 m³ or with explosive atmospheres is strictly prohibited.
- The system installer **MUST** issue a Declaration of compliance for the work performed after commissioning the system, in accordance with the laws in force related to system safety standards.
- The installation technician must inform the user on safe equipment use.
- The installation operator is responsible for the installation and is therefore required to perform the work to top workmanship standards.
- **The appliance must be connected to a combustion product exhaustion flue built in accordance with applicable standards and certified with a declaration of compliance.**
- Should any installation defects arise during the optional Commissioning service, the specialised Technical Service Center, can refuse to endorse use of the product for safety reasons and submit a written Servicing Report to the User informing him that he and the Installation operator shall be jointly liable for any damage to persons, animals or things if used.
- Before installing the machine, the customer and installation operator must ensure that the flooring on which it will be positioned is suitably levelled and can support the weight (see **CHAP.06 - TECHNICAL DATA**). If there is any doubt on the solidity of the flooring, it is essential to have a Structural Engineer verify relative installation feasibility.
- Only specialised and qualified personnel may work or carry out checks inside the machine, complying with safety regulations.
- Prior to installation, the user and installer are obliged to check that the mains electrical supply to which the machine will be connected, corresponds to the voltage on the identification plate (see **CHAP.05.2 - PRODUCT IDENTIFICATION**), check that the system is sized so as to bear the maximum load required of the product, and also that it is equipped with



all suitable safety devices to classify the electrical system as COMPLIANT with applicable safety standards. If this is not the case, contact a Qualified Technician to adapt the system to required standards.

- The power cord plug must be connected only AFTER the conclusion of the installation and assembly of the device, and must remain accessible after installation if the device does not have a suitable and accessible double-pole switch.
- Personnel assigned to handling the machines and equipment must always wear industrial gloves and boots.
- The Maintenance Operator must recommend the Customer to sign an annual maintenance contract for the product, so as to maintain the levels of safety and efficient performance of the product.
- The Maintenance Operator must check the working hours of the product between one maintenance intervention and another, to verify the actual work load of the stove. The actual hours of operation shall be reset at the end of the Technical intervention and indicated on the Servicing Report.

02.4 EQUIPMENT FOR OPERATORS AND MAINTENANCE PERSONNEL

Every operator performing maintenance on the machine, must wear safety garments and personal protective equipment:



1 Protection headphones



2 Gloves hand protections



3 Respiratory mask



4 Face mask or goggles



5 Accident prevention boots



6 Overalls or smock

02.5 RESIDUAL RISKS

Though JOLLY MEC CAMINETTI S.p.A. does everything within its power to produce its systems with the greatest competence regarding safety and consulting all the directives, laws, and regulations available, there are still, if minor, some residual risks during the phases of:

- TRANSPORT AND INSTALLATION
- ELECTRICAL CONNECTIONS (Which must be done by a qualified electrician)
- MAINTENANCE

Therefore, the technicians who perform these tasks must take these residual risks into account.

WARNING



Removal or tampering with the protection and safety devices can be only be done voluntarily and may cause serious injury to people.
Replace the safety signals when they become illegible or come off.

CHAP.03 HANDLING AND TRANSPORT

03.1 RECEIVING GOODS

The product is delivered on pallets, packaged in a cardboard box with a cellophane wrapping. when receiving merchandise, check that:

- all packaging is intact
- all of the merchandise indicated on the delivery bill has actually been delivered
- the supply corresponds to the order specifications;
- if the packaging is damaged, check the condition of the contents, because any breakages must immediately be reported to the carrier and to the retailer.
- check there is no damage to any supplied elements; if there is any breakage detected, report it as soon as possible to the carrier and to the retailer.

If any material listed on the delivery note is missing, report it to the retailer as soon as possible.

WARNING

Danger of suffocation



Make sure that children do not come into contact with packaging materials, plastic film or polystyrene as this could cause suffocation.

03.2 LIFTING AND TRANSPORT

Personnel in charge of handling the product must have read and thoroughly understood the safety prescriptions in **CHAP.02 - ACCIDENT PREVENTION / SAFETY REGULATIONS** of this manual and must wear work gloves and safety footwear. For safety reasons, unauthorised persons must not be in the area while the product is being moved.

The product must be moved only with a trolley or pallet fork, and never with belts, chains, overhead cranes (see **CHAP.06 - TECHNICAL DATA** for the weight). All parts of the packaging coming into contact with the crane, belts or straps must be protected. Unless there are obstacles, lift the product to a maximum of 30 cm from the ground and move it slowly, avoiding jerky or brusque movements.

WARNING

Danger of crushing, collision and abrasions.



CHAP.04 ECOLOGICAL REGULATIONS

04.1 DISPOSAL OF THE MACHINE



Directive 2012/19/UE (waste electrical and electronic equipment - WEEE): information for users.

The crossed-out wastebasket symbol on the appliance means that at the end of its useful lifespan, the product must be disposed of separately from ordinary household wastes.

The user is responsible for delivering the appliance to an appropriate collection facility at the end of its useful lifespan.

Appropriate separate collection to permit recycling, treatment and environmentally compatible disposal helps prevent negative impact on the environment and human health and promotes recycling of the materials making up the product.

For more information on available collection facilities, contact your local waste collection service or the shop where you bought this appliance.

NOTE



The machine must be disposed of in a manner that complies with the laws in force and the environment.
When taking it to the disposal firms, handle the stove as described in **CHAP.03 - HANDLING AND TRANSPORT.**

WARNING



Danger of environmental pollution

Adopt positive civic behaviour and DO NOT disperse the packaging into the environment, but take it to waste disposal centres for recycling. All packaging can be recycled, as it consists of wood, polyethylene film, polystyrene and cardboard

END-OF-LIFE DISPOSAL OF THE EQUIPMENT COMPONENTS (REGULATION (EU) 2015/1185 - Annex II - par. 3 - a) - 3)

INSTRUCTIONS FOR CORRECT PRODUCT DISPOSAL

The owner is fully and exclusively liable for stove demolition and disposal according to laws in force in his/her country regarding safety, respect and protection of the environment. At the end of its useful life, the product must not be disposed of together with urban waste. It can be delivered to the appropriate differentiated collection centres set up by the municipal administrations, or to retailers that provide this service. Differentiated product disposal allows you to avoid possible negative consequences for the environment and health, deriving from its inappropriate disposal, and allows you to recover the materials of which it is composed in order to obtain significant energy and resource savings.

The following table and the related exploded view to which it refers highlight the main components that can be found in the appliance and the indications for their correct separation and disposal at the end of their life.

More specifically, electrical and electronic components must be separated and disposed of at authorised disposal facilities, in compliance with European Directive 2012/19/EU and relevant national transpositions.

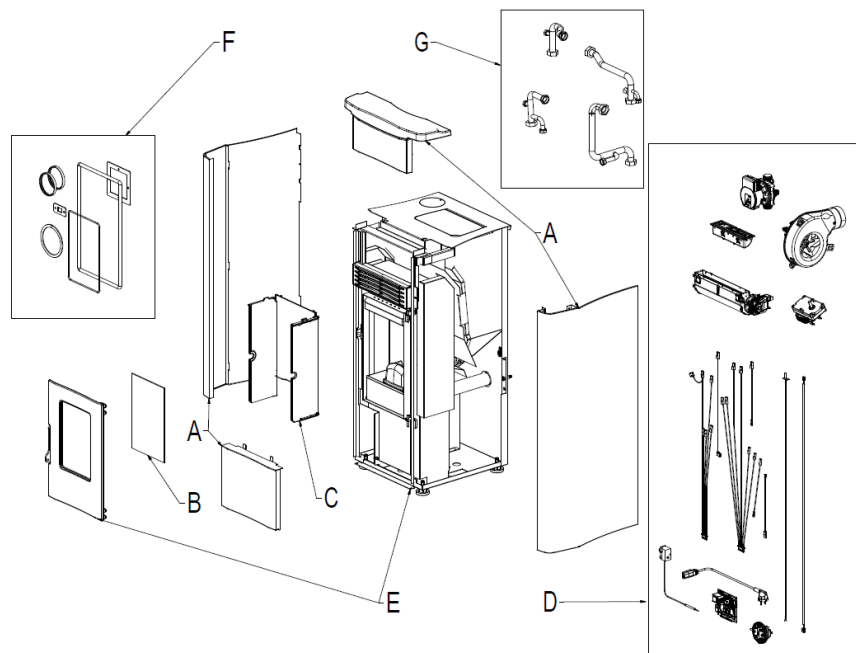

<p>A. EXTERNAL CLADDING If present, dispose of separately as per type of material:</p> <ul style="list-style-type: none"> - Metal - Glass - Tiles or ceramics - Stone 	<p>C. INTERNAL CLADDING If present, dispose of separately as per type of material:</p> <ul style="list-style-type: none"> - Metal - Refractory materials - Insulation panels - Vermiculite - Insulation, vermiculite and refractory materials that have come into contact with flame or flue gases (dispose of in mixed waste)
<p>B. GLASS DOORS If present, dispose of separately as per type of material:</p> <ul style="list-style-type: none"> - Glass ceramic (fire door): dispose of in aggregates or mixed waste - Tempered glass (furnace door): dispose of in glass 	<p>D. ELECTRICAL AND ELECTRONIC COMPONENTS Wiring, motors, fans, circulators, displays, sensors, spark plugs, electronic boards. Dispose of separately at authorised collection facilities in compliance with the WEEE Directive 2012/19/EU.</p>
<p>E. METAL STRUCTURE Dispose of separately into metal</p>	<p>G. HYDRAULIC COMPONENTS Pipes, fittings, expansion tank, valves. If present, dispose of separately as per type of material:</p> <ul style="list-style-type: none"> - Copper - Brass - Steel <p>Other materials</p>
<p>F. NON-RECYCLABLE COMPONENTS I.e: Seals, hoses made of rubber, silicone or fibres. Dispose of in mixed waste</p>	

CHAP.05 DESCRIPTION

05.1 PRODUCT PRESENTATION

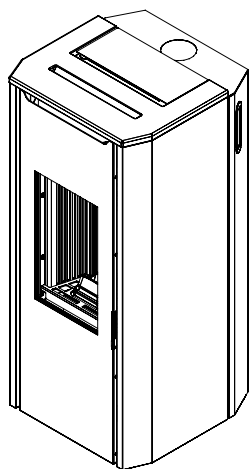

PADDY 6 kW
PADDY 8 kW

Jolly-Mec products are the result of over forty years experience in the wooden biomass combustion sector; they are designed and engineered to meet the increasing demands of today's markets with high performance levels and a modern design.

The PADDY 6 kW and PADDY 8 kW stoves for air and pellets are heating systems approved to EN 14785:2006 European Standard requirements issued by an independent body accredited by the European Commission for machine commissioning and certification.

The PADDY 6 kW and PADDY 8 kW stoves are high efficiency products providing air heating, fuelled by an alternative and renewable energy source: Wooden PELLETS.

A design that is always up to date, maintaining the tradition and irreplaceable cosiness of a warm home.

These are heating systems with state-of-the-art features; they have a robust structure, a FIRE FLECTOR cladding in the combustion chamber and a heat exchanger where a fan is used to circulate the air to heat the environment.

The particular constructional features allow it to reach a comfortable temperature extremely quickly using reduced amounts of fuel.

Combustion is controlled by an electronic control unit with the following main functions and features:

- **Remote control with Display:** Wide backlit LCD display allowing operators to interface with the product, set the operating parameters and receive work status data.
- **Timer-controlled thermostat:** used to set the start-up and switch-off times along with relative temperatures.
- **Ambient temperature:** setting and viewing of the current ambient temperature on the display.
- **Output levels:** possibility to adjust the heat output to five different levels and to set the Silent mode.
- **Operating mode:** displays real time product operating modes.
- **Multi-language:** choice of five European languages.

They are also fitted with:

- PELLET hopper (for the capacity see specifications).
- A practical drawer to collect the ashes.
- Thermal safety device against possible overheating.
- Safety device against possible clogging of the flue pipe.
- Tangential fan for the exchange of air in the environment.
- Fume exhaust fan.
- Electrical resistance to start combustion.

NOTE



The various elements of the cladding must be handled carefully, as being satin-finished, polished or painted, they could be scratched or dented during the handling or assembly phases.

The chromatic variations of the painted surfaces, especially those in different materials and finishes and subject to different temperatures, cannot be deemed reason for dispute as they depend upon the natural characteristics of the materials and the use of the product.

WARNING



PELLET combustion products must only be used with the combustion chamber door closed.

05.2 PRODUCT IDENTIFICATION

It is **COMPULSORY** to indicate the product MODEL, the LOT number and SERIAL NUMBER in all communications with the Manufacturer. Identification numbers are printed on the adhesive plate located on the back of the device as illustrated on the right. Stove performance values measured during inspection tests according to the indicated reference and EC markings are also included on the plate.

 <small>LEADER IN RESIDENTIAL HEATING</small> Via San Giuseppe, 2 - 24060 Telgate - BG - ITALY Tel. +39.035.8359211 - fax +39.035.8359200 www.jolly-mec.it - info@jolly-mec.it		
n° DOP JM00182 the dop was drafted on the basis of the test report of accredited laboratory the accreditation number of the laboratory is 2456 TÜV Rheinland Energy GmbH		
Apparechio per il riscaldamento domestico alimentato a pellet di legno - Residential space heating appliance fired by wood pellet - Mit Holzpellets befeuerte Wärmezeuger für den Wohnbereich - Appareil de chauffage domestique alimenté au pellet de bois - Aparato para calefacción domestica alimentado con pellets de madera		
L'apparechio non può essere utilizzato in canna fumaria condivisa - The appliance can not be used in flue shared - Das Gerät kann nicht in gemeinsamen schornstein verwendet werden - L'appareil ne peut pas être utilisé dans conduit partagé - El aparato no se puede utilizar en tubo de humos compartido		
Potenza termica nominale Rated heat output Nenn-Heizleistung P _{ts}	6,3 kW Nominal 2,9 kW Reduced	Potenza bruciata Burned power Max Heizleistung P _{ts}
Rendimento Efficiency Wirkungsgrad Rendement Rendimiento	93,5 % Nominal 95,1 % Reduced	CO emissioni CO emissions CO emission Emission de CO Emission de CO
Temperatura dei fumi Flue gas temperature Abgastemperatur Température des fumées Temperatura de los humos	112,4 °C Nominal 73,5 °C Reduced	Emissioni polveri Dust emissions Emission poussières Staubemissionen Emission de polvo
Potenza elettrica nominale Rated electrical power Elektr. Leistungsaufnahme P _{max} P _{max} Potenza elettrica nominale 48 W Working	Tensione/Frequenza nominale Rated voltage/frequency Spannung/Nennfrequenz Tension/Fréquence nominale Tension/Frecuencia nominal	Qtot Nominal Reduced
Distanza minima materiali combustibili adiacenti Min. clearance from combustible materials Abstand zu angrenzenden entzündlichen Stoffen Distance aux matériaux combustibles Distancia a materiales combustibles adyacentes	F= S= B= 	
Leggere e seguire le istruzioni di funzionamento Read and follow the operating instructions. Lesen und befolgen Sie die Betriebsanleitungen Lire et suivre les instructions de fonctionnement Leer y seguir las instrucciones de funcionamiento Utilizzare solo combustibili raccomandati Use recommended fuels only Verwenden Sie nur die empfohlenen Brennstoffarten Utiliser seulement des combustibles recommandés Utilizar sólo los combustibles recomendados	N° lotto: Cod: Matr: 	Pellets - Granulé de bois

- 1 Product model
- 2 CE marking
- 3 Year of commissioning and certification
- 4 Reference standard
- 5 Performance declaration No.*
- 6 Product LOT N°
- 7 Product code
- 8 Product serial number

WARNING



*Pursuant to European Regulation No. 305/2011, manufacturers are now required to have the DoP - Declaration of Performance for each product of own design concerned; Jolly-Mec did namely provide all of these documents in downloadable electronic form that you can easily see on the website of the Company at the following address: <http://www.jolly-mec.it>.

NOTE



The illustrated example plate may differ in graphics from the original affixed to the product.

CHAP.06 TECHNICAL DATA

06.1 HOMOLOGATION

Technical specifications resulting from laboratory tests conducted according to EN 14785:2006 test methods at the CERTIFICATION institute.

Description	PADDY 6 kW	PADDY 8 kW	UM
Nominal burning output	6,9	9,0	kW
Nominal heat output	6,4	8,2	kW
Reduced heat output	2,4	2,4	kW
Nominal output consumption	1,432	1,870	Kg/h
Reduced output consumption	0,53	0,53	Kg/h
Nominal output efficiency	92,0	90,6	%
Rated voltage	230	230	V
Rated frequency	50	50	Hz
Electrical absorption (Switching on - nominal power - reduced power - stand-by)	310 - 60 - 15 - 2,2	310 - 65 - 15 - 2,2	W
Device mass	105	105	Kg
Standard hopper capacity	15	15	Kg
Flue draught (Nominal heat output - Reduced heat output)	10,0 - 8,0	10,0 - 8,0	Pa
Fume exhaust diam.	80	80	mm
Average fume Temperature at nominal output	134,7	167,8	°C
Average fume Temperature at reduced output	91,3	91,3	°C
CO (13% O ₂) at nominal output	61	113	mg/m ³
CO (13% O ₂) at reduced output	461	461	mg/m ³
CO ₂ at nominal output	11,22	12,52	%
NOx (13% O ₂) at nominal output	158	139	mg/m ³
OGC (13% O ₂) at nominal output	2	3	mg/m ³
Polveri (13% O ₂) at nominal output	20	20	mg/m ³
Nominal fume mass output	4,4	5,2	g/s
Reduced fume mass output	2,5	2,5	g/s
Average heated area*	43 - 67,7	55,2 - 86,7	m ²
Minimum air distance from inflammable side wall	200	400	mm
Minimum air distance from inflammable rear wall	100	100	mm
Frontal air distance from inflammable material	900	900	mm
Comburent air pipe diameter	50	50	mm
Energy efficiency class	A+	A+	-

The declared output may vary according to fuel type.

The above technical specifications were measured with certified quality PELLETS. ONLY use this type of fuel as recommended later in **CHAP.06.2 - RECOMMENDED FUELS**.

*According to the typology of building and insulation (Referred to the need of 55 W/m³ and 35 W/m³; room height 2,7 m).

WARNING



All appliance tests, final inspection and fine-tuning was performed using the recommended certified pellets.. Jolly Mec Caminetti S.p.A. is not responsible for malfunctions, breakdowns or problems due to the use of pellets that are not recommended, as combustion parameters vary according to the quality of the pellets.

To achieve best operational results, it may be necessary to change the default factory settings on the control unit during the optional Commissioning service. These operations must only be performed by a specialised Technical Service Center.

06.2 RECOMMENDED FUELS

WARNING

PELLET QUALITY IS VERY IMPORTANT; PLEASE READ THIS SECTION CAREFULLY



A pellet product's performance is significantly linked and highly influenced by the type and quality of wooden pellets that is burned. It is important to choose pellets that have no debris or impurities. The Association of Pellet Manufacturers with the Italian Thermotechnical Committee have established standards for identifying pellets in terms of energy*.

As the efficiencies of different wooden PELLETS qualities differ, likewise the efficiency and heat capacity emitted by the product running on pellets will vary. Similarly, unburned residue left in the combustion chamber is inversely proportionate to pellet quality: the lower the pellet purity, the faster dirt accumulates in the machine.

Jolly Mec Caminetti S.p.A recommends the use of the same type of pellets used during the optional Commissioning service, i.e. when the settings and calibrations were made to suit the loaded combustible materials. Continuous switching of types and qualities of combustible materials will require continuous adjustments to settings by the specialised Technical Service Center, which can not be endorsed by the Manufacturer.

The main quality certifications for PELLETS on the European market are **DIN Plus**, **Ö-Norm M7135** and **UNI EN ISO 17225-2** (class A1 or A2), which guarantee the following quality standards:

*CERTIFIED PELLET CHARACTERISTICS

Powder	1% maximum through a 3.2 mm screen
Apparent density	680 Kg/m ³ minimum
Dimensions	6 mm diameter from 25 to 30 mm of maximum length
Ash content	1% maximum
Humidity	8% maximum
Heating power	4,9 kWh/Kg
Packaging	in eco-compatible or biodegradable material sacks

Store pellets at least 1 m from the appliance, in a dry place and not outdoors, not even under porches or roofings.

Do not use pellets that are very hard and with different dimensions; the mechanical parts are sized and tested for use with pellets with the above-mentioned characteristics.

No breakdown or malfunction depending on the quality of the pellets used and/or by the dosage of the quantity will be covered by the warranty.

NOTE

WHAT YOU SHOULD KNOW ABOUT PELLETS:



pellets are obtained by a drawing process using sawdust discarded by virgin wood processing systems and therefore have no chemical additives. The consistency, compactness and strength with which the pieces remain intact is due to a substance contained in wood called lignin; this acts as a binder during the compression phase.

The various qualities of combustible materials can also depend on the sawdust mix used to produce the pellets, which generally have a standard length of between 5 and 30 mm, a diameter of between 5 and 6 mm, a weight of from 600 to 700 Kg/m³ and a humidity of no more than 8% of its weight.

One advantage over wood is its greater heating power; in fact, when using good quality wood, it is possible to achieve about 4.3kWh/Kg with a humidity rate of up to 15%, whilst with pellets this can climb to 4.9kWh/Kg and a water content of a maximum of 8%.

The sacks of pellets must be stored in a clean, dry place.

06.3 COMPONENTS

The device is supplied with the following components:

- Installation, use and maintenance manual.
- Use and maintenance accessories (see CHAP.08.6 - ORDINARY MAINTENANCE).
- Power cord to connect the stove to the mains.
- Cladding.
- Remote control.

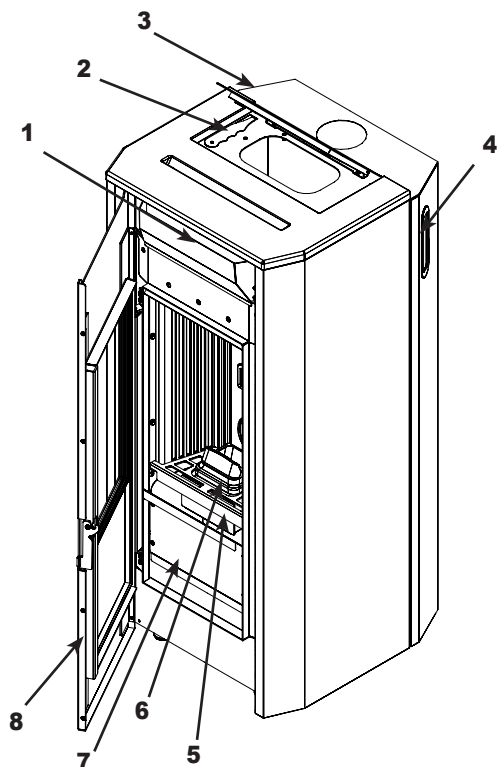

Part List:

1. Hot air outlet
2. Handle for opening the door
3. Lid for loading pellets
4. Emergency console
5. Combustion chamber grid
6. Firebox
7. Ash drawer
8. Combustion chamber door
9. Pellet hopper
10. Electronic control unit
11. Fume pressure switch
12. Comburent air inlet tube Ø50 mm
13. Room temperature probe
14. Safety thermostat with manual reset
15. Electrical socket with fuses and Main electric switch
16. Heating fan
17. Combustion and fume exhaust fan Ø80 mm
18. Pellet loading auger gear motor
19. Pellet loading auger
20. Electrical heating element for lighting

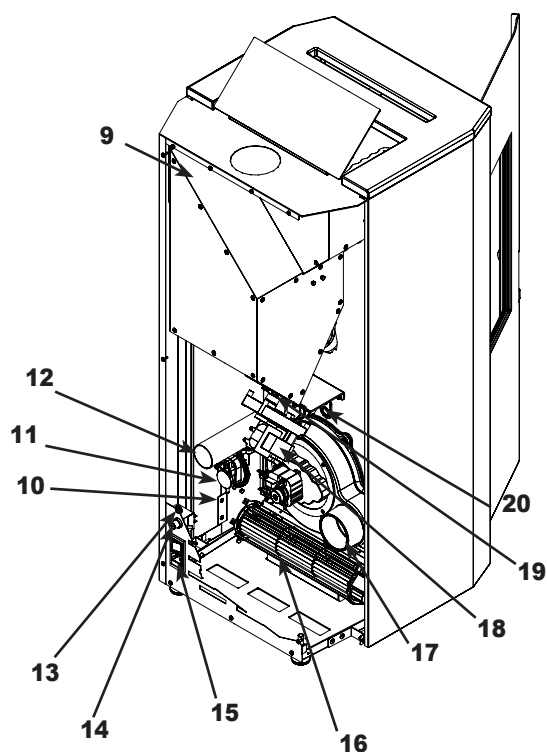

06.4 DIMENSIONS

All measurements are in mm.

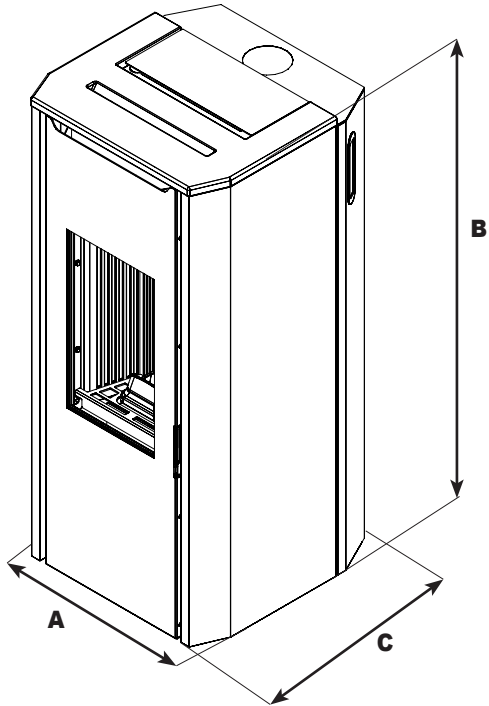

	PADDY 6 kW PADDY 8 kW
A	471
B	1080,4
C	485,6

PADDY 6 kW - PADDY 8 kW

CHAP.07 POSITIONING AND CONNECTIONS FOR THE INSTALLER

07.1 SETTING UP OF EXTERNAL AIR INTAKES AND ELECTRIC CURRENT

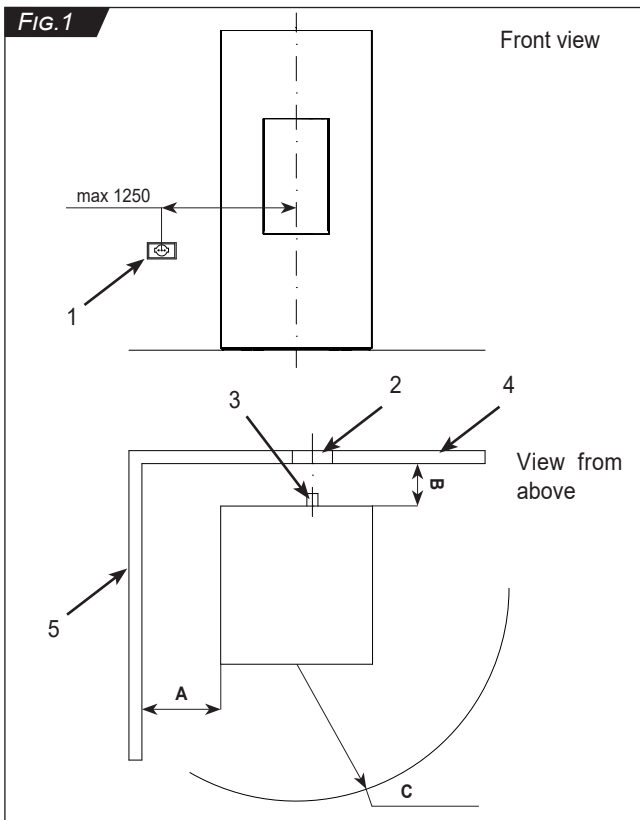

The device must only be installed indoors and on surfaces that can support the load. If the existing construction does not meet this requirement, it will be necessary to take appropriate measures (e.g. installing a load distribution plate). The appliance must be installed in an area where the appliance itself, gas exhaust pipes and flue can be easily accessed for maintenance.

FIG. 1 illustrates minimum distances that must be observed, all measures must be in mm.

The lateral distance from the adjacent wall, according to installation, is to be maintained on both sides.

1. Electrical socket
2. External air inlet (see chap. 07.4)
3. Comburent air intake
4. Rear panel
5. Side panel

NOTE As indicated in the national reference standard UNI 10683, the product can not be installed in rooms with a volume of under 15 m³.

NOTE Bear in mind that the minimum distances from inflammable materials are:

PADDY 6 kW:
 Minimum air distance from inflammable side wall (A): 200 mm
 Minimum air distance from inflammable rear wall (B): 100 mm
 Frontal air distance from inflammable material (C): 900 mm
PADDY 8 kW:
 Minimum air distance from inflammable side wall (A): 400 mm
 Minimum air distance from inflammable rear wall (B): 100 mm
 Frontal air distance from inflammable material (C): 900 mm
 as indicated in **CHAP.06.1 - HOMOLOGATION**

- View from the back (main quotes for carrying out installation)

PADDY 6kW - PADDY 8kW

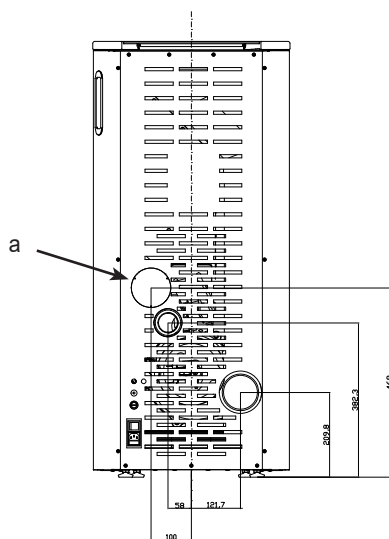

a: Outlet for hot air ducting Ø80 mm

NOTE The external air intakes must be made so that they cannot get accidentally covered and if they have an insect protection mesh they must be cleaned periodically to prevent clogging with dust and dirt, especially in periods with intense pollen concentrations.

07.2 FLUE OR FUME EXHAUST SYSTEM

The flue or fume exhaust system is a fundamental element for the proper functioning of the stove and must comply with the following general standards:

EN1856-1	Chimneys. Requirements for metal chimneys - Part 1: System chimney products
EN1856-2	Chimneys. Requirements for metal chimneys - Part 2: Metal flue liners and connecting flue pipes
UNI 10683	Heat generators operating with wood or other solid bio fuels - Installation requirements

The diameter of the flue must be sized according to the technical specifications of the appliance and type and place of installation. Each appliance must have its own chimney flue without any inlets from other appliances.

The exhaust duct of the combustion products generated by the forced draught equipment must respond to the following requirements:

- it is necessary to use union joints and pipes with pressure resistant seals, as the union of the flue could be slightly pressurised while the appliance running
- all changes in direction must be open to inspection to facilitate maintenance
- correct draught to maintain depression in the combustion chamber, as per the technical specifications, must be guaranteed
- it must be watertight, waterproof and suitably isolated and insulated
- must be made of suitable materials that resist normal mechanical stress, heat, the action of the combustion products and acid condensations
- must be prevaillingly vertical structures with deviations from the axis not greater that 45°
- must be adequately distanced from combustible or inflammable materials via an air space or suitable insulation
- must have an internal section which is preferably circular: square or rectangular sections must have rounded corners with a radius of no less than 20 mm
- must have an internal section that is constant, free and independent

If the flue is installed externally it must be insulated to prevent the cooling of fumes and formation of condensation. The same is valid for the tract from the roof to the chimney cap (Torrino). For the union between the stove and the flue, or if there are deviations or curves, for easier, quicker and safer installation, we recommend using double-walled stainless steel pipes.

The use of pipes in fibre cement for connecting the equipment to the flue is forbidden.

Exhaust pipes must not run through rooms where the installation of combustion equipment is forbidden. The union must be connected to the flue in such a way as to ensure they remain airtight when the appliance is operating in pressurised conditions and to avoid the formation of condensation and its conveyance to the appliance.

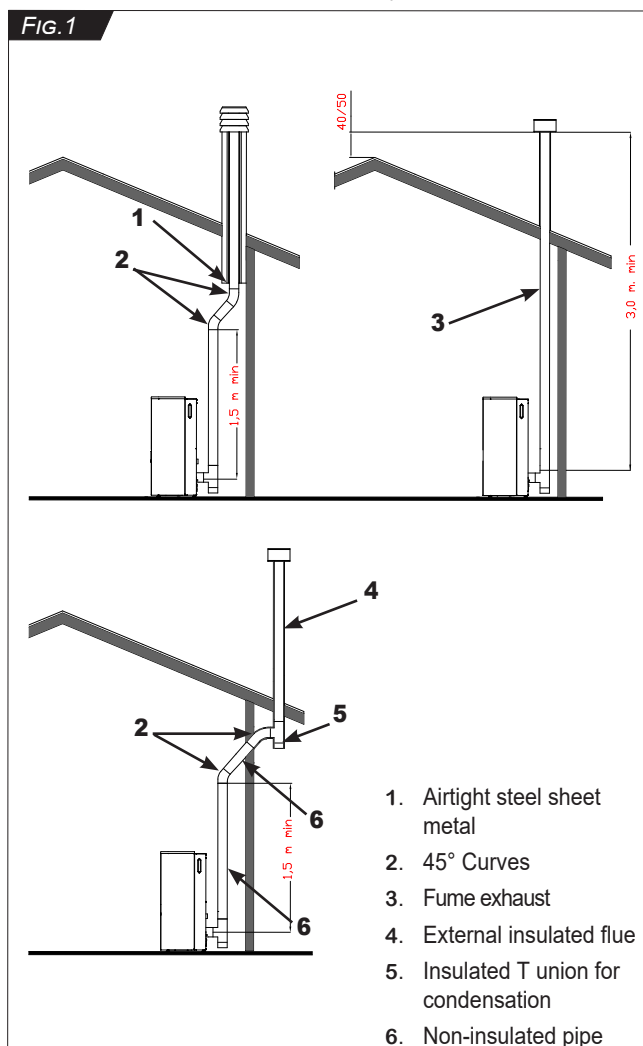

It has to be avoid, as much as possible, the assembly of horizontal sections. In any case, the horizontal segment (or its horizontal projection) do not have to be longer than two meters with minimum slope not less than 5%. The horizontal section does not have to be connected directly to the smoke fan output but after the first vertical segment (6) *FIG. 1*.

The chimney system for the smoke exhaust MUST be dimensioned and projected by a Qualified Engineer. He will determine the proper smoke exhaust system taking into consideration the product technical data, kind of installation, installation location and mostly the installation technical regulation in force. The Engineer will give indications to the installer about the materials to use, smoke path section, insulation thickness, corrosion resistance and all requirements needed for the correct working of the system product-chimney.

The correct dimension of the air intake for ventilation and aeration of the installation location **MUST** be verified in conformity with the technical regulation in force.

Malfunctioning of the product caused by a smoke exhaust not properly projected and dimensioned WILL NOT be object of objections to Jolly-Mec and interventions at Jolly Mec charge.

For appliance that must reach ceiling or wall exhaust outlets that are not coaxial with regard to the issue of the fumes from the machine, changes in direction must be made using an open elbow of 45° (see *FIG. 1*).

The use of counter slope elements is forbidden. The flue union must have a constant section and allow soot to be collected and swept away. Changes in cross-section are only allowed at the outlet of the heat generator: the use of adaptors on the coupling with the chimney flue is prohibited.

Running other air ducts and installation pipes inside the exhaust pipes, even if oversized, is forbidden.

In the event of a black-out, suitable sizing of the fume exhaust system guarantees sufficient draught to exhaust the fumes generated by combustion without the use of the electric exhaust fan.

If the performance of the fume exhaust system is not excellent, it is possible to adjust the operating settings of the stove to overcome draught defects by a maximum of 15% of the fume exhaust device; this adjustment is however the exclusive competence of the specialised Technical Service Center.

Supporting the weight of the flue with the appliance union is strictly forbidden. Use specific stands or independent supports for this purpose.

To install other combustion devices in the same room where the pellet appliance is installed, refer to UNI 10683 and UNI 7129 installation regulations.

The minimum flue height must be over 3,0 m.

Blocking of wall exhaust terminals at any height and any distance from openings, doors and/or windows is not permitted and a very important rule to follow.

Installation of external fireplaces must be performed using insulated double-walled pipes, to prevent the formation of condensate; it must also be possible to inspect the base of the fireplace for routine maintenance which must be done at least once a year.

A windproof chimney cap must be installed; in the presence of adverse weather conditions, especially high winds, this accessory allows the stove flue draught system to operate much easier.

A minimum flue draught between 10 and 14 Pa must be guaranteed. This value must be measured using specific and controlled instruments each time the appliance and flue undergo maintenance.

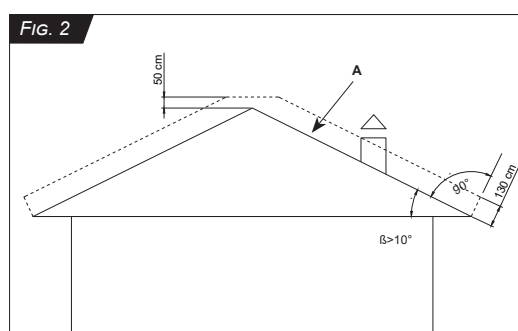

With strong winds and the chimney cap installed in the reflux area (see FIG. 2, zone bordered by the dotted line A for roofs with $\beta > 10^\circ$ slant) of the roof or without complying with the distances foreseen by UNI 10683 situations may arise where the stove does not work which will trigger the no depression alarm.

It is not possible to make corrections or reset the stove operating values to override the alarm.

07.3 INSTALLATION ROOM VENTILATION

According to reference regulation UNI10683, 4 Pa depression must be verified between the installation room interior and exterior. Prepare ventilation openings of at least 80 cm² in the room where the product is installed to allow the inflow of clean oxidizing air taken from unpolluted rooms. The ventilation openings, if fitted with insect-proof mesh, must be easily removable and undergo periodic cleaning to ensure clear air flow passage.

If the comburent air inlet is directly connected to the stove, it may be necessary to make adjustments to the control unit, especially during the start-up phase, as the temperature and humidity of outdoor air not only varies during the period of use of the product, but also come into direct contact with the pellets and the ignition element, generating different fuel burning times.

Here below you will find the indications for the realization of externally connected direct air intake:

- Over a length of 0 to 1 m, the diameter of the air intake fitting shall be 80 mm, with only 1 possible change of direction of 90° maximum, and a difference in height of up to 50 cm downwards or 20 cm upwards.
- On a length between 1 m and 3 m, the diameter of the air intake fitting must be 100 mm, with only one change of direction of up to 90° and a height difference of up to 50 cm downwards and 20 cm upwards.
- Above 3 meters, and up to 5 meters maximum, the diameter of the air intake fitting must be 125 mm, always with only one change of direction of up to 90°, and a difference in height of up to 50 cm downwards and 20 cm upwards.

Jolly Mec authorizes a direct air intake fitting above 5 m on products and recommends an installation only under technical project.

In order to ensure a proper installation and good operation of the product, Jolly Mec offers an external air intake fitting as an option: diameter 80 mm for a maximum developed length of 1 m.

WARNING



As per the fuel product exhaust system, air vents are also extremely important and must be given the appropriate consideration and respect.

The installer is directly liable for all electrical system parts, generation hook-up to the system, ventilation and the fume exhaust system and MUST, at the end of installation work, issue a declaration of conformity as per Ministerial Decree 37/08.

On the other hand, the purchaser MUST assign all work to a qualified professional technician.

The device must be installed and used in accordance with all local and national laws and EC Regulations.

NOTE



It is only recommended to connect the comburent air ducting system to the stove if absolutely necessary. Very cold air and humidity may cause difficulties during the stove ignition phase.

WARNING



It is not allowed to install coaxial systems for the smoke output.

07.4 ASSEMBLY SEQUENCE

1. Unpack the stove by removing the cardboard. Place the stove in the location where you want to install it. When choosing the place to install it, remember that installation must guarantee easy access to clean the stove, the fume pipes and the flue, and that the safety distances must be complied with as provided for in **CHAP.06.1 – HOMOLOGATION**.
2. For assembling the cladding please see the specific annexes (see AD197).
3. The stove may function by taking the combustion air directly from the outside (see paragraph 07.3 for the external combustion air canalisation characteristics) or from the inner part of the installation room (in this case, a ventilation opening needs to be designed, in compliance with the specifications in paragraph 07.3).
4. All models may be connected to the fume pipes with rear fume outlet (*Fig. 1*) or with upper fume outlet (*Fig. 2*) (see AD199). For the construction of fume pipes please comply with the specifications in CHAP. 07.2.

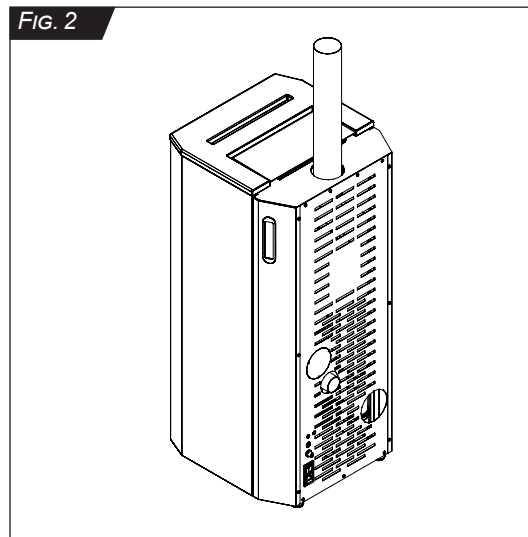
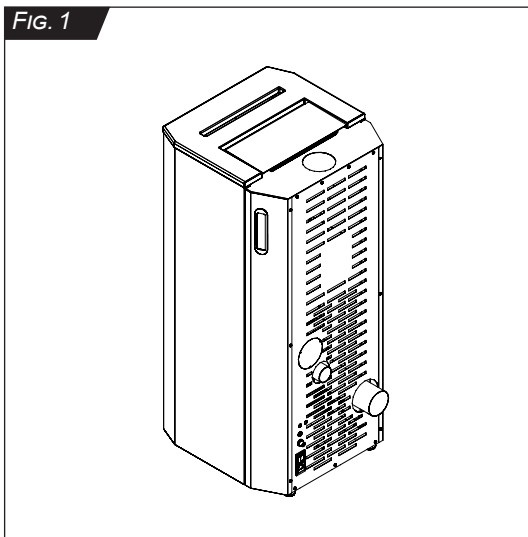

07.5 ELECTRICAL CONNECTIONS

Connect the 230Vac 50Hz line with the proper cable with plug, supplied with the stove, which powers up the control unit and all the appliance's electrical components

The device is equipped with a power socket with fuses and a bipolar switch.

In the event that the control unit does not switch on, even after turning the switch to I "ONE", check that the fuses are intact.

1. Control unit
2. Earth
3. Power socket with cord included
4. Switch
5. Fuse Ø5X20 F4A 250V IEC 127-II

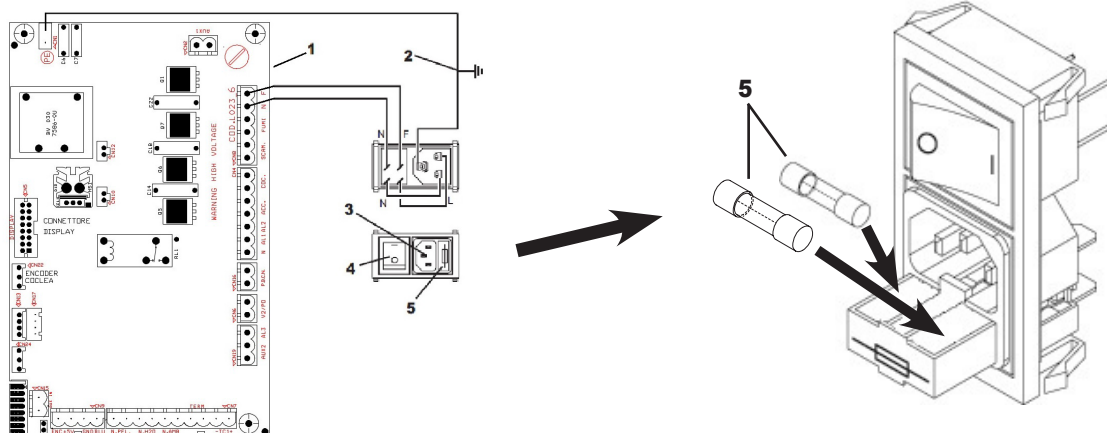

WARNING Electrical connections must be carried out by skilled personnel according to the regulations in force (2014/30/UE and 2014/35/UE).

!

Connecting the power socket

Before connecting the plug on the cord supplied with the stove to the domestic electrical system, plug it into the socket fitted on the back of the stove (Fig.1-2) and make sure the switch is on the "O" position.

After inserting the plug into the power socket, press the switch O – I on pos. "I".

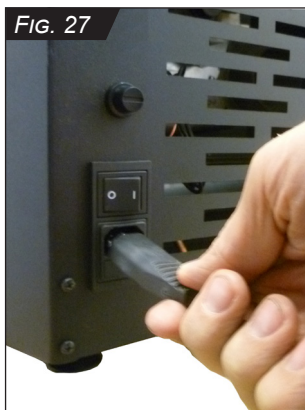

WARNING

Pay attention that the power cord does not touch hot parts.



07.6 CONTROL UNIT ELECTRICAL WIRING DIAGRAM

WARNING



Electrical connections must be carried out by skilled personnel according to the regulations in force (2014/30/UE and 2014/35/UE).

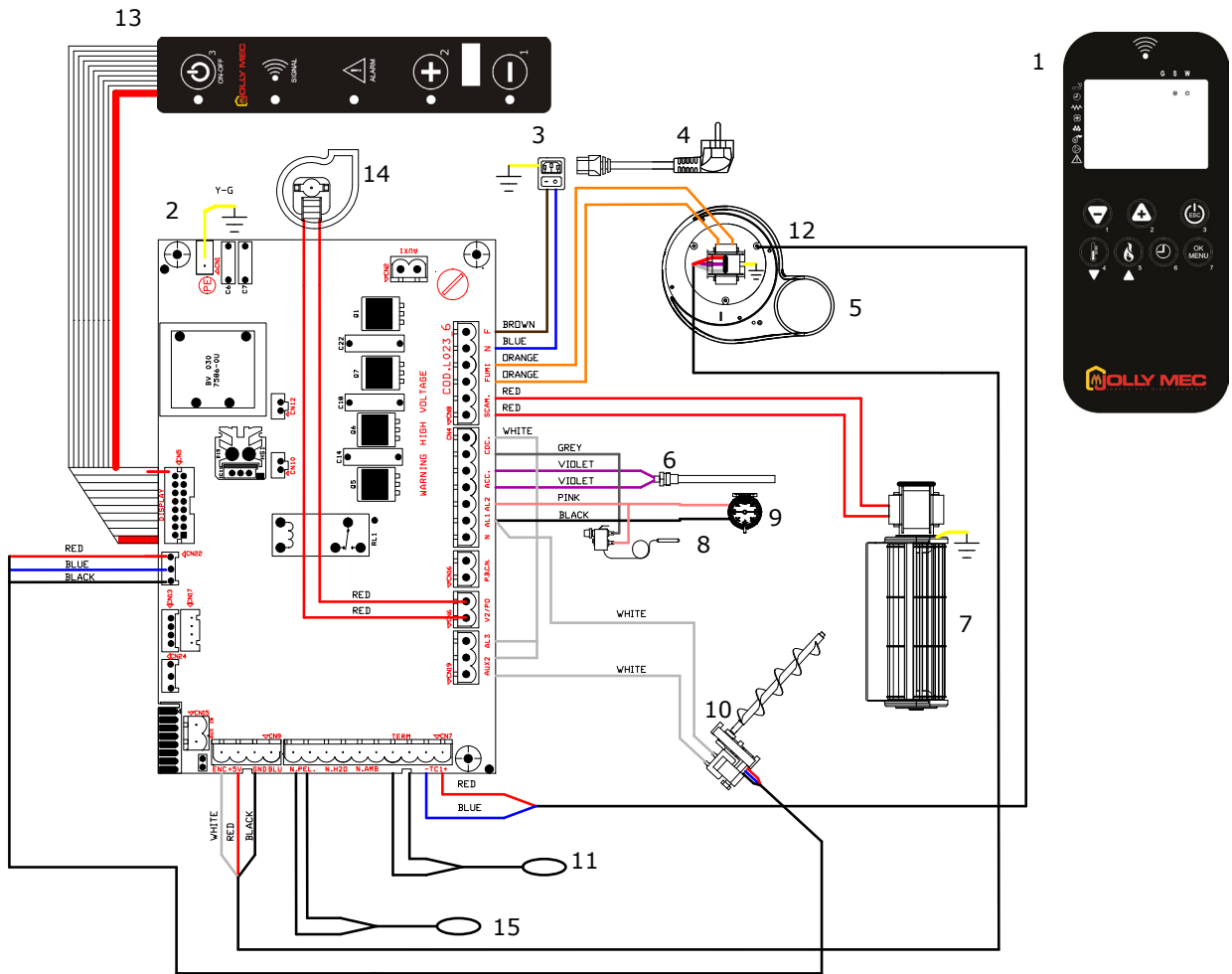

Number	Description
1	Radio control
2	Electronic card
3	Bipolar switch
4	Electric power cord with schuko socket
5	Smoke fan
6	Electrical heating element
7	Exchange fan
8	Bulb type safety thermostat

Number	Description
9	Fume pressure switch
10	Pellet loader gear motor
11	Ambient probe
12	Smoke probe
13	Emergency control console / radio antenna for radio remote control
14	Ducting fan (optional)
15	Ambient probe/Ducting fan thermostat (optional)

NOTE



The representation of the components is approximate, but they can change in terms of shape.

07.7 EXAMPLE OF AIR DUCTING IN THE VARIOUS ROOMS

NOTE



To duct air into the other rooms, connect the pipe to the stove's rear outlets in order to distribute the air inside all rooms. The air can be balanced with the grids with adjustable closures.

The air pipes must be brought to the rooms to be heated.

From every room where hot air is ducted, the air must return to the stove room through openings beneath the doors or vents, which must be taken up again by the grid behind the stove.

Air is distributed with flexible circular pipes in aluminium Ø80 mm. The pipes must be fastened to the unions with pipe clamps.

Pipe insulation is vital for the stove's performance. They must be wrapped with glass wool pads (minimum thickness 3 cm) along its entire length.

Warning: makes sure that pipes do not contact wood and inflammable materials.

It is also very dangerous to use plastic pipes to distribute air since the high temperatures could deform them and release harmful gases. Where it is impossible to wall up the distribution pipes, they can be hidden with a suspended ceiling, fake beams or casing.

NOTE



It is vital to build a balanced air ducting system (as regards the length of the air distribution pipe in the rooms, that should be up to 6 m), so as to achieve both excellent heat distribution and performance in all ducted rooms.

It is also recommended, in order to improve further the distribution and decrease the noise of the ducted air, to use pipes with a smooth inside.

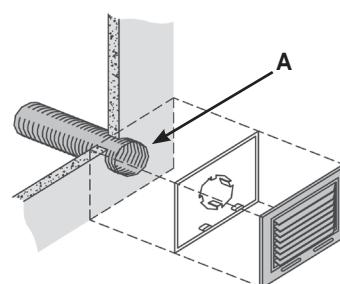

The space (A) between the vents and the wall must be hermetically sealed with silicone, to prevent leaking air from blackening it due to heat (for instance smudges above radiators).

WARNING

IMPORTANT: Use a neutral cure silicone seal



Please see AD195 for assembling the canalisation fan.

CHAP.08 USE AND MAINTENANCE FOR THE USER

08.1 APPLIANCE OPERATIONS

The STOVE uses pellets as fuel, whose combustion is electronically controlled.

Pellets are taken from the storage hopper by the auger controlled by the gear motor and conveyed directly to the burn pot. They are ignited by the hot air produced by the electric heating element (E) and aspirated into the burn pot by the centrifugal fan which is the same that sucks up the fumes produced by combustion, expelling them to the rear part of the stove.

The room air tangential fan moves the air into the space on the back of the fireplace, where it is heated and then released into the environment through the front outlet. Located on the rear part of the stove, the hopper is filled by an openable lid located on the upper part of the cladding. Pellets must be placed in the hopper with a shovel and not directly poured from the bag.

CHAP. 08.6 ORDINARY MAINTENANCE (By the customer).
The fireplace is equipped with an exchanger in steel and dual heat developing FIREREFLECTOR, closed in front by a door in ceramic glass. The quantity of fuel, the feeding of comburent air and the extraction of fumes are regulated with an electronic card in order to obtain a highly efficient combustion.

The whole management of the product is made through the display and the PDA provided (see manual SM095 attached).

08.2 CONTROL UNIT

The electronic control unit, connected by radio frequency to the radio remote control, manages all the device functions and the LCD display screen on the handheld console can be used to monitor all the stove operating phases.

The electronic control unit features a timer function with customisable programmes and a user-friendly operating settings. Operations are controlled by the ROOM PROBE in the remote control or standard installed at the back of the appliance, that can be prolonged to the installation room in a more appropriate position to correctly measure room temperature. It can be used as an ambient thermostat, paying GREAT ATTENTION that the electrical connection to the stove motherboard is CLEAN

The electric/electronic elements also include certain safety systems such as:

FUME TEMPERATURE PROBE	Fitted inside the fume exhaust fan
PRESSURE SWITCH	Connected to the fume exhaust fan
SAFETY THERMOSTAT	Triggers when temperature in the appliance is too high



The radio remote control lets you use the following main functions:

- Device start and stop
- Heat output level control
- Regulate the desired ambient temperature.
- Optimise combustion.
- Manually load pellets into the basket.
- Manage the timed thermostat with several daily start ups, weekly start ups and for week-ends.
- Report any function irregularities.
- Indicate the heating appliance's operating mode.

In the event of radio remote control fault, main appliance functions can be controlled from the emergency console installed under the pellet cover.

NOTE

For a full and detailed description of the content in this section, see the enclosed manual SM0095.



08.3 APPLIANCE START AND USE

After professionally installing the room ventilation system, the fume exhaust system and electrical system according to the relevant regulations, the specialised Technical Service Center can provide the optional Commissioning service.

Follow these steps to start using the product: load pellet of the recommended quality in the tank, set the desired temperature and heat output level (we recommend setting level 3) and press Button 3 to turn on the device.

Whilst operating, with the WORK message on the control unit display, the device has a heating output according to one of the 5 levels of output set. The device remains in operating mode; i.e. at the heat output level, until the set ambient temperature is exceeded by 0.5 °C. At this point it will switch to the ECO mode function. The device will switch back to WORK mode when the ambient temperature decreases 1.0°C below the SET ambient temperature.

When operating in WORK mode, the fan speed for the hot air exhausted through the grid depends on the output levels; the higher the output level, the faster the air will be pumped through the front grid.

With STAND-BY, MENU 5 mode enabled, it is possible to switch off the device if the ambient temperature conditions are satisfied within the values set for the OFF Delta temperature value. The OFF Delta, is the temperature differential between the SET ambient temperature and the actual ambient temperature. Therefore if, for instance, the SET ambient temperature is 19°C, with an OFF Delta of 2°C and a switch-off delay of 5', when the ambient temperature remains above 21°C for at least 5 minutes, the device will switch off. The device will remain in STD-BY until the ambient temperature reaches 1°C of the SET ambient temperature which correspond to the automatic start-up value of the stove. In this condition, the stove is not actually off but is waiting to turn back on if the above conditions are satisfied.

Set SET CHRONO – MENU 2 to time operation start and stop. The crono can be quickly started by pressing Button 6 on the main display screen. CHRONO and STAND-BY modes cannot be activated simultaneously. The CHRONO function should be considered as a timer function, while STAND-BY is a temperature function.

In the event of alarms and/or manual pellet load from MENU 7, message CLEAN BASKET is a warning to be sure not to turn on the stove with excessive pellets in the brazier. To cancel the message, clean the brazier and press and hold down Button 3 for three seconds. Loading must be performed if the auger is empty, after a NO PELLETS alarm, or after maintenance or cleaning of the container. Every time the manual pellet load mode is enabled, the firebox MUST be emptied to create the correct conditions for the stove start-up phase.

The device can be switched off while operating with manual intervention by the user or by setting a SET-TIMER or can switch off if an alarm is triggered following a device malfunction.

In the second case follow the indications provided in CHAP. 09 - FAULT DIAGNOSIS AND TROUBLESHOOTING.

WARNING



The device must only be used with the combustion chamber door closed.

The pellet hatch must be closed while the machine is running.

The stove starting MUST ALWAYS be performed with clean and empty firebox.

WARNING



The installation technician must attend the optional Commissioning service since system components may require adjustments not pertinent to the specialised Technical Service Center at this time.

Any additional work or intervention of the specialised Technical Service Center due to the failure to complete the above adjustments during the optional Commissioning service are at the user's expense.

08.4 SAFETY THERMOSTAT WITH MANUAL RESET

A safety thermostat is installed on the device to protect against any overheating of fuel contained in the pellet hopper and cause the device to switch off if the temperature sensor reaches limit values which correspond to the thermostat trigger setting. To restore normal appliance operations following forced shutdown by a thermostat, proceed as follows:

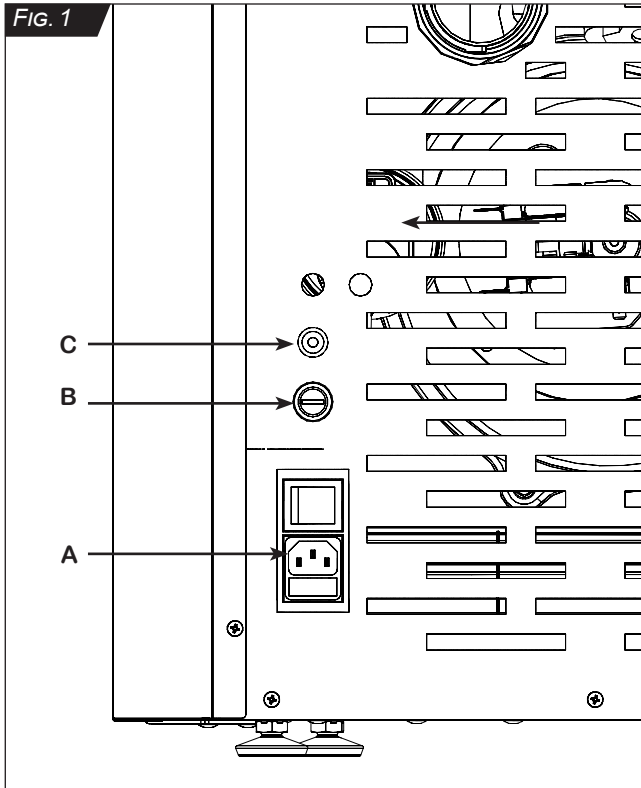

1. Wait until the appliance is completely cold (on average 20 minutes);
2. Unscrew the thermostat reset button lid on the back of the appliance (see Fig. 1, positions B);
3. Press the button until you hear a CLICK;
4. Refit the hood;
5. Reset the alarm from the radio remote control by pressing the button 8 and waiting for the OFF message;
6. Start up again the appliance.

If the alarm persists, contact the specialised Technical Service Center.

Socket unit (Fig. 1):

- A. Electrical socket with bi-polar switch and fuse protection (see CHAP.07.5 - ELECTRICAL CONNECTIONS)
- B. Thermal safety thermostat
- c. Room temperature probe

08.5 TIPS FOR THE USER

- Use only original spare parts recommended by the manufacturer. Original spare parts are available through retailers, specialised Tecnical Service Centers, or directly at the head office of Jolly Mec Caminetti S.p.A.
- If the glass becomes very dirty (with visible blackening) while operating on pellets, possible causes could be:
 - low draught by the flue (clean the flue or check its characteristics).
 - Insufficient comburent air (add more air with the combustion fan), clean the air intake.
- When pellets are not used for a long time (spring-summer period), the hopper, the auger and the basket must be completely emptied using a vacuum cleaner; clean carefully to prevent that pellet residue deposits there and damages components during the next start up.
- Only use recommended fuels under penalty of cancellation of the warranty.
- Generally with a good quality product, every 500-1000 kg of pellet loaded in the hopper, check that there are no deposits of sawdust on the bottom, and remove any sawdust there (sawdust reduces the auger's capacity and creates functional problems for the stove). With low quality or non-certified pellets the frequency with which the bottom of the hopper needs cleaning to remove sawdust could become more frequent.
- The pellets must be fed into the hopper using a scoop. Do not empty the sack directly into the hopper.
- Check for obstructions in the flue and in the external air intake before starting the machine after a prolonged period of disuse.
- The stove must not be used as an incinerator. Do not use fuels that are not recommended.
- The stove must not be modified; any unauthorised modification will automatically invalidate the warranty and release the manufacture from all liability.
- The stove must not be placed in direct contact with combustible materials (see **CHAP 06 - TECHNICAL DATA**)
- Prompt and systematic maintenance is a fundamental component for perfect operating performance and continuous maximum heat efficiency.

MORE CLEANING = HIGHER PERFORMANCE

- Annually it is necessary to perform extraordinary cleaning unit by specialized Technical Service Centre, see **CHAP.08.7 - SCHEDULED PREVENTIVE MAINTENANCE**).

WARNING

Call the Fire Brigade if a fire occurs in the flue.



WARNING

- Pellet combustion products must only be used with the combustion chamber door closed. NEVER open it during operations.



Never run the fireplace without electrical current and with fuels other than wood pellets.

DO NOT TOUCH the parts of the fireplace without cladding, excluding the handles and the regulating controls, as they are subject to high temperatures.

The room where the fireplace is installed must not directly adjoin multi-floored stairwells; there must not be other boilers, stoves or air extractors in the same room (except for "C" type appliances).

08.6 ORDINARY MAINTENANCE (by the costumer)

WARNING

Before starting any type of cleaning, switch off the main switch and make sure that the appliance is cold. Never restart the stove before completing these operations and correctly reassembling all components.

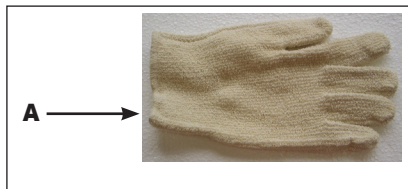

Cleaning tools supplied

A) Heat proof glove

To facilitate and improve device cleaning, use an ash vacuum (not supplied with the stove but available from retailers and/or specialised Technical Service Centers).

• **ORDINARY CLEANING**

THE INSTRUCTIONS BELOW REGARDING THE TIMING AND METHODS USED FOR THE VARIOUS PARTS TO BE CLEANED MUST BE CAREFULLY FOLLOWED.

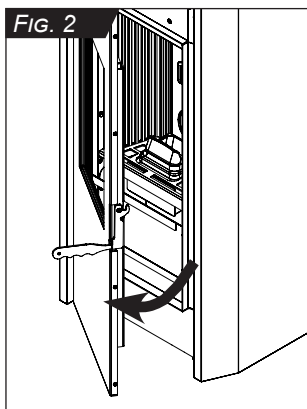
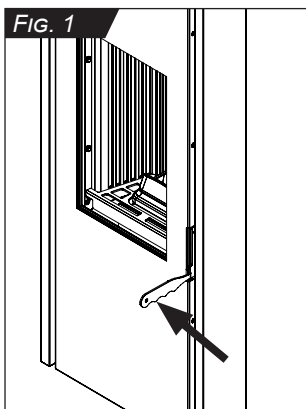

1. Stove door opening

To open the stove combustion chamber door use the handle supplied with the product to open the lock then pull to fully open (FIG. 1-2-3). Close the door making sure it is correctly locked. Periodically check seam sealing integrity inside the door (FIG. 3).

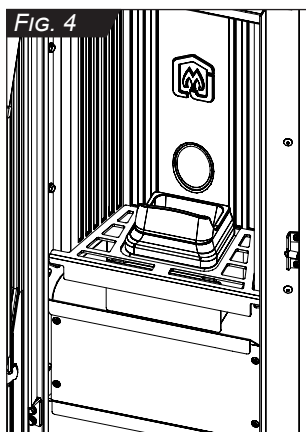
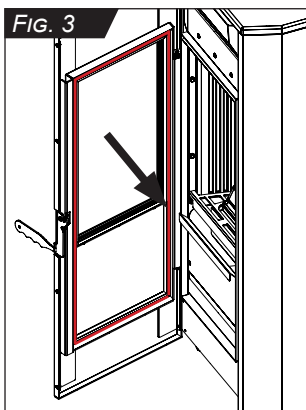

2. Stove body cleaning

Remove the firebox (as described in point 3. **Remove the firebox to clean it**) and remove the flame-breaker (as described in point 8. **Remove the flame-breaker**).

Use a brush to clean the internal walls of the combustion chamber in the FIRE FLECTOR allowing the soot to fall into the pan (FIG. 4). Remove the ash pan, empty it and accurately clean (as described in point 4. **Ash pan removal and cleaning**).

Eventually use a vacuum cleaner, with cold residual ashes, to suction any soot and ash left inside the ash pan compartment.

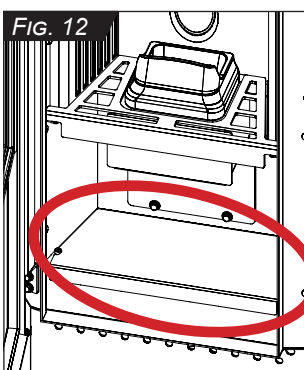
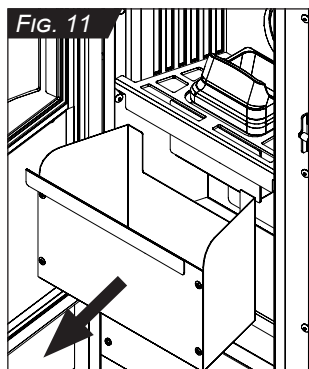
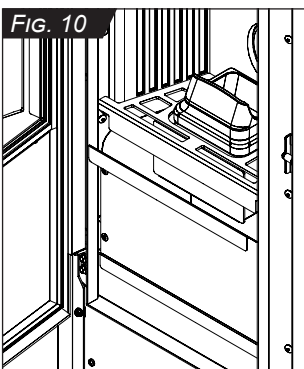
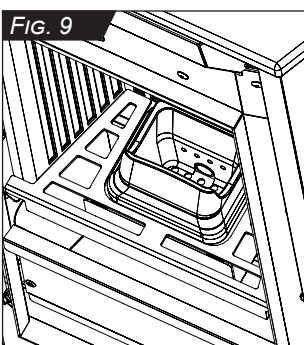
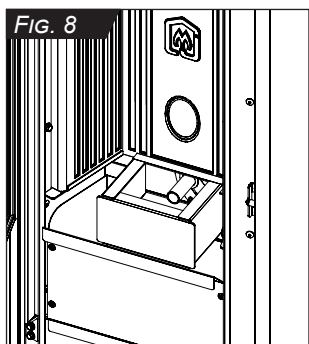
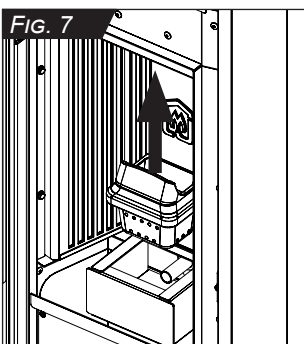
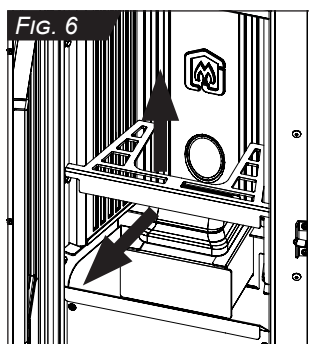
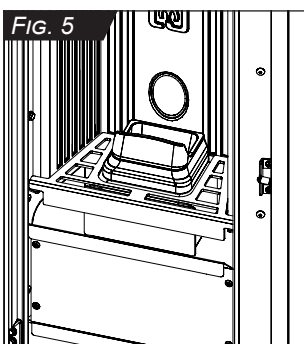

3. Remove the firebox to clean it

Leave the combustion chamber door open, remove the grid and take the firebox away, by lifting it in vertical position (FIG. 5-6-7). It is compulsory to clean the firebox thoroughly, making sure no holes are clogged.

Eliminate the wastes on the firebox by overturning them and use a pointed object to remove any scales, by hitting the firebox internal walls and shaking it eventually.

Before replacing the firebox, check there is no ash or dirt in the firebox housing. Vacuum this area thoroughly too (make sure residual ashes are cold) (FIG. 8).

Make sure that the area where the firebox rests is cleaned well (if the firebox does not sit well on it and air passes, the stove will not start up and operates poorly).

After cleaning the firebox, make sure it is repositioned correctly in its housing as indicated (FIG. 9).

The electric igniter element must be centred correctly in its seat in the firebox and the seat must be perfectly in line with the housing.

4. Ash pan removal and cleaning

With the combustion chamber door open, extract the drawer positioned inside the stove at the bottom (FIG. 10-11). After removing and emptying the drawer it is recommended to vacuum the drawer housing to remove any ash residue (make sure residual ashes are cold) (FIG. 12).

Use a "drum type" vacuum cleaner equipped with a fine mesh filter, which will simplify cleaning as it prevents the vacuumed ash from returning to the environment. When finished, make sure the pan is correctly positioned.

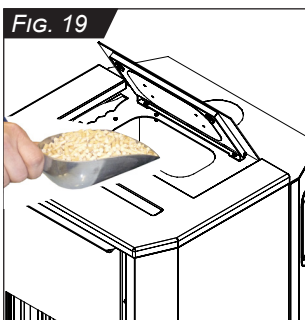
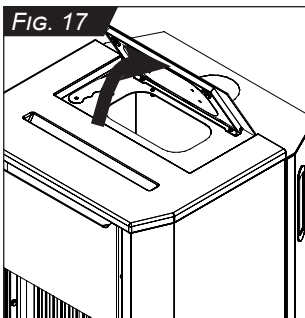
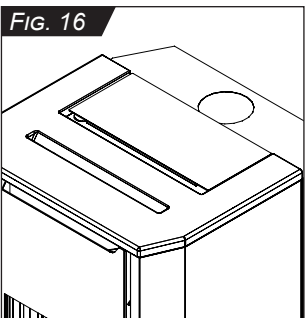
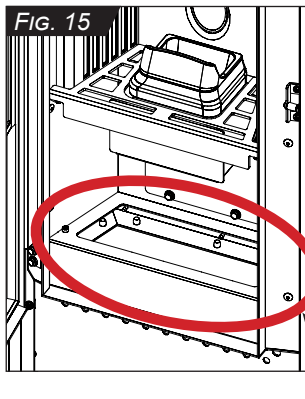
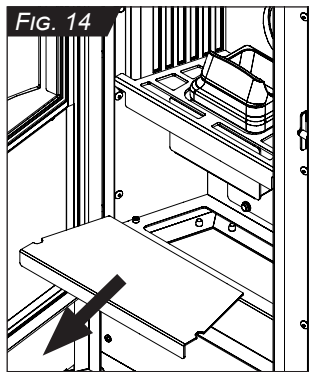
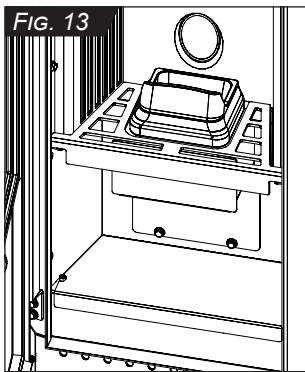

5. Fume inspection cleaning

Remove the inspection cover under the ash pan and clean carefully this space.

Use the ash vacuum spout to suction all the residual ash left at the bottom of the exchanger entering the inspection hatch with the ash vacuum handle (make sure residual ashes are cold) (FIG. 13-14-15).

After cleaning, place the inspection cover as installed previously.

6. Pellet tank opening for cleaning and loading

Apply light pressure to lift the pellet hopper cover, pulling upwards, to release the magnet closure (FIG. 16-17).

Empty the pellet container every 500-1000 Kg of pellet burnt, and check that no sawdust has accumulated on the bottom. Clean the bottom of the container carefully.

After a long period of inactivity, empty the container and auger completely.

Located on the rear part of the device, the hopper is filled through an openable lid. The hopper must be filled with pellets using a shove (not supplied) (FIG. 18-19) and not poured in directly from the bag.

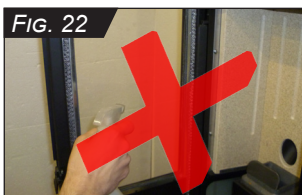

7. Glass cleaning

Clean the glass daily with a damp sponge or paper hand towels (FIG. 20-21). If the glass becomes dirty with black smoke, the brazier is probably dirty or the combustion air must be increased. Be careful not to use overly aggressive products to avoid ruining the paint. Never spray detergents directly onto the parts to be cleaned (FIG. 22-23).

If the stove requires more frequent and deeper cleaning, check the flue draught performance and the chimney cap. A windproof chimney cap is strongly recommended.

Also clean the outside window where necessary (FIG. 24).

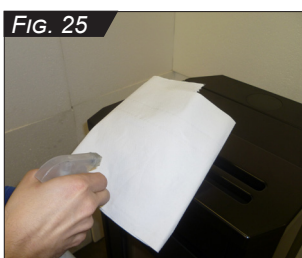

8. Cladding cleaning

For cleaning the cladding only use neutral water-based detergents that must be used to wet a cloth and pass it on it (FIG. 25-26). Never spray detergents directly on cladding parts (FIG. 27).

Use of abrasive and/or corrosive chemical products can damage the painted parts and are reason for invalidation of the warranty on these parts.

The chromatic variations of the painted surfaces, especially those in different materials and finishes and subject to different temperatures, cannot be deemed reason for dispute as they depend upon the natural characteristics of the materials and the use of the product.

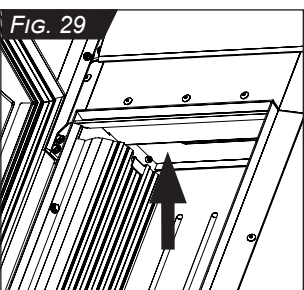
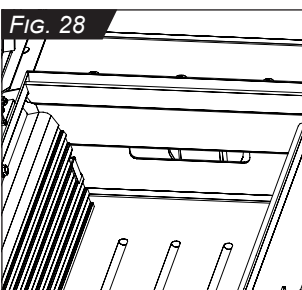

9. Remove the flame-breaker

To remove the flame-breaker (FIG. 28), inside the combustion chamber, lift it to move it from side supports and bending its left side part, by accompanying it carefully downwards, until the piece is totally out of the combustion chamber (FIG. 29-30-31). Clean the flame-breaker by removing the deposited ashes.

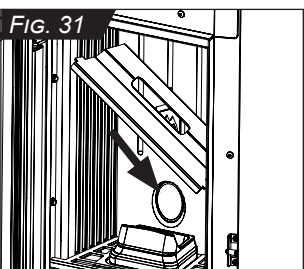
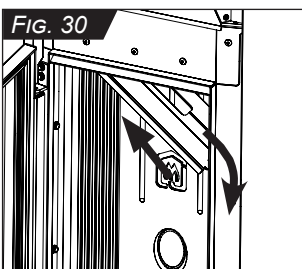

08.7 SCHEDULED PREVENTIVE MAINTENANCE (To be done by a specialised Technical Service Center)

We wish to remind you that the Extraordinary Maintenance to be carried out on this type of product must be done obligatorily every year by qualified maintenance personnel, in order to maintain its functionality, efficiency and comfort.

For any further queries you may have, we invite you to contact the specialised Technical Service Center through your retailer. Scheduled maintenance must include:

- Cleaning of the flue (with special focus on horizontal segments)
- Stove fume pass cleaning
- Cleaning of any deposits in the stove
- Cleaning of fans
- Check good ignition resistance operations
- Check electric/electronic system integrity
- Check safety device, thermostat and pressure switch status and efficiency
- Check the condition of the sealing gaskets, paying special attention to the one on the closure of the combustion chamber door.
- Check the condition of the ceramic glass.
- Check the pellet loading gear motor is working properly.
- Clean the bottom of the pellet hopper.

WARNING



To carry out these operations, the appliance must be disconnected from the mains; wait until the appliance is cold and comply rigorously with the safety regulations in force

Device cleaning and maintenance schedule chart.

Description	Daily	Weekly	Monthly	Annually	As necessary
Stove body cleaning		U			
Brazier removal for cleaning	U				
Ash pan removal and cleaning	U				
Fume inspection cleaning			U		
Pellet tank cleaning			U		
Glass cleaning	U				
Cleaning the cladding					U
Remove the flame-breaker		U			
Cleaning of the flue				T	
Stove fume pass cleaning				T	
Cleaning of any deposits in the stove				T	
Cleaning of fans				T	
Check good ignition resistance operations				T	
Check electric/electronic system integrity				T	
Check safety device, thermostat and pressure switch status and efficiency				T	
Check the condition of the sealing gaskets, paying special attention to the one on the closure of the combustion chamber door.				T	
Check the condition of the ceramic glass.				T	
Check the pellet loading gear motor is working properly.				T	
Clean the bottom of the pellet hopper.				T	

KEY: U: routine maintenance by the customer user
T: extraordinary maintenance by a specialised Technical Service Center

NOTE

Time between one cleaning and the next is strictly tied to fuel quality and also the device's operating time. The most suitable cleaning frequency can only be established a few days after use according to the actual amount of deposited residue and may vary from the intervals imposed by Jolly Mec.

CHAP.09 FAULT DIAGNOSIS AND TROUBLESHOOTING

09.1 PROBLEMS

WARNING



In accordance with the laws in force on safety for electrical appliances, a specialised Technical Service Center or qualified personnel must obligatorily be contacted for all installation, maintenance or interventions that require access to electrical parts.

PROBLEM	MAIN CHECKS TO BE PERFORMED
The Emergency Display is not on	<ul style="list-style-type: none"> • Check that the stove plug is inserted securely in the mains socket and the socket at the back of the stove. • Check that the FLAT cable is connected to the electronic circuit board correctly. • Check that the protection fuses are working efficiently, including those connected to the electronic circuit board and those in the stove rear socket.
The radio remote control does not work	<ul style="list-style-type: none"> • Check that the batteries are the ALKALINE type and not 1.5 V AA rechargeable batteries, and they are inserted correctly. Do not use rechargeable batteries. • Point the radio remote control at the display on the edge of the stove. • Check that the stove is powered up and the display is working.
The pellets are not dropping into the firebox	<ul style="list-style-type: none"> • The pellets have run out, refill the container. • The gear motor is not running, check the reason: <ul style="list-style-type: none"> - not connected to the mains - mechanically disconnected from the auger. • The auger is blocked by a foreign body which has fallen into the container. • The auger is blocked by very hard pellets; use the recommended pellet types. • The auger is blocked by a safety device triggered by the manual reset thermostat or the fumes safety pressure switch.
The stove does not start automatically	<ul style="list-style-type: none"> • The firebox is dirty, preventing incoming air flow. Clean it thoroughly and check it is clean each time you start it up. • The basket is positioned incorrectly. • The resistance is faulty
The pellets burn incorrectly and unburnt elements gather in the basket, the glass looks black and is very dirty	<ul style="list-style-type: none"> • Low flue draught, do not use the fireplace, it could be dangerous; carefully clean the flue, the stove and the fume extractor. • Firebox is very dirty. Switch off the stove and clean it. • Humid pellets. Replace the fuel. • Lack of comburent air, check that the front door is firmly shut against the stove structure. • Incorrect fan settings; check the default and factory settings.
The stove switches off when running at minimum power.	<ul style="list-style-type: none"> • The combustion fan speed is very high and the pellets are burning too quickly. • The pellet supply is running out. • The flue draught rate is high. • The amount of loaded pellet is high, it does not all burn within the set time and fresh pellets accumulate inside the firebox. Adjust the load level, or increase the combustion fan speed.
The flame is very inconsistent	<ul style="list-style-type: none"> • Check the bottom of the pellet container; there may be large deposits of sawdust. • The gear motor may have broken gearings.
The exchange and/or combustion fan are running when the stove is switched off	<ul style="list-style-type: none"> • The flue probe is broken. Replace it
The electric components are running when the stove is switched off	<ul style="list-style-type: none"> • The electronic circuit board is broken. Replace it.
The exchange fan air smells of smoke	<ul style="list-style-type: none"> • Check the exchange fan, it might be dirty.
The exchange fan whistles or is very noisy	<ul style="list-style-type: none"> • Check the exchange fan, it might be dirty.

NOTE

For a detailed list of alarm messages, see the enclosed manual SM095.



CHAP.10 ANNEXES

10.1 COMMISSION REGULATION (EU) 2015/1185

Information requirements for solid fuel local space heaters ACCORDING TO COMMISSION REGULATION (EU) 2015/1185

Manufacturer	JOLLY-MEC CAMINETTI SPA
Trademark	JOLLY MEC
Model identifier(s)	PADDY 6 kW
Indirect heating functionality	no
Direct heat output	6,4 kW
Indirect heat output	-
Reference standard	EN14785
Notified Body	TÜV Rheinland Energy GmbH - NB 2456 - Am Grauen Stein, D-51105, Köln

Fuel	Preferred fuel (only one):	Other suitable fuel(s)	η_s [%]	Space heating emissions at nominal heat output (*)				Space heating emissions at minimum heat output (*) (**)					
				PM	OGC	CO	NOx	PM	OGC	CO	NOx		
				[mg/Nm ³ – 13%O ₂]				[mg/Nm ³ – 13%O ₂]					
Wood logs with moisture content ≤ 25 %	no	no											
Compressed wood with moisture content ≤ 12 %	yes	no	81	20	2	61	158						
Other woody biomass	no	no											
Non-woody biomass	no	no											
Anthracite and dry steam coal	no	no											
Hard coke	no	no											
Low temperature coke	no	no											
Bituminous coal	no	no											
Lignite briquettes	no	no											
Peat briquettes	no	no											
Blended fossil fuel briquettes	no	no											
Other fossil fuel	no	no											
Blended biomass and fossil fuel briquettes	no	no											
Other blend of biomass and solid fuel	no	no											

(*) PM = particulate matter, OGC = organic gaseous compounds, CO = carbon monoxide, NOx = nitrogen oxides
 (**) Only required if correction factors F(2) or F(3) are applied.

Please comply with the specific installation, assembly, use and maintenance precautions indicated in the manual supplied with the product.

Characteristics when operating with the preferred fuel

Heat output

Item	Symbol	Value	Unit
Nominal heat output	P_{nom}	6,4	kW
Minimum heat output (indicative)	P_{min}	2,4	kW

Useful efficiency (NCV as received)

Item	Symbol	Value	Unit
Useful efficiency at nominal heat output	$\eta_{th,nom}$	92,0	%
Useful efficiency at minimum heat output (indicative)	$\eta_{th,min}$	92,8	%

Auxiliary electricity consumption

Item	Symbol	Value	Unit
At nominal heat output	eI _{max}	0,060	kW
At minimum heat output	eI _{min}	0,015	kW
In standby mode	eI _{SB}	0,002	kW

F(4)	1,0%
------	------

Permanent pilot flame power requirement

Item	Symbol	Value	Unit
Pilot flame power requirement (if applicable)	P _{pilot}	N.A.	kW

F(5)	0,0%
------	------

Type of heat output/room temperature control (select one)

Item	Value
Single stage heat output, no room temperature control	no
Two or more manual stages, no room temperature control	no
With mechanic thermostat room temperature control	no
With electronic room temperature control	yes
With electronic room temperature control plus day timer	no
With electronic room temperature control plus week timer	no

F(2)	0,0%
------	------

Other control options (multiple selections possible)

Item	Value
Room temperature control, with presence detection	no
Room temperature control, with open window detection	no
With distance control option	no

F(3)	0,0%
------	------

Contact details

Contact details	JOLLY-MEC CAMINETTI SPA Via San Giuseppe 2, Telgate (BG), 24060, IT info@jolly-mec.it - +39 0358359211
-----------------	---

**Information requirements for solid fuel local space heaters
ACCORDING TO COMMISSION REGULATION (EU) 2015/1185**

Manufacturer	JOLLY-MEC CAMINETTI SPA
Trademark	JOLLY MEC
Model identifier(s)	PADDY 8 kW
Indirect heating functionality	no
Direct heat output	8,2 kW
Indirect heat output	-
Reference standard	EN14785
Notified Body	TÜV Rheinland Energy GmbH - NB 2456 - Am Grauen Stein, D-51105, Köln

Fuel	Preferred fuel (only one):	Other suitable fuel(s)	η_s [%]	Space heating emissions at nominal heat output (*)				Space heating emissions at minimum heat output (*) (**)				
				PM	OGC	CO	NOx	PM	OGC	CO	NOx	
				[mg/Nm ³ – 13%O ₂]				[mg/Nm ³ – 13%O ₂]				
Wood logs with moisture content ≤ 25 %	no	no										
Compressed wood with moisture content ≤ 12 %	yes	no	80	20	3	113	139					
Other woody biomass	no	no										
Non-woody biomass	no	no										
Anthracite and dry steam coal	no	no										
Hard coke	no	no										
Low temperature coke	no	no										
Bituminous coal	no	no										
Lignite briquettes	no	no										
Peat briquettes	no	no										
Blended fossil fuel briquettes	no	no										
Other fossil fuel	no	no										
Blended biomass and fossil fuel briquettes	no	no										
Other blend of biomass and solid fuel	no	no										

(*) PM = particulate matter, OGC = organic gaseous compounds, CO = carbon monoxide, NOx = nitrogen oxides
 (**) Only required if correction factors F(2) or F(3) are applied.

Please comply with the specific installation, assembly, use and maintenance precautions indicated in the manual supplied with the product.

Characteristics when operating with the preferred fuel

Heat output

Item	Symbol	Value	Unit
Nominal heat output	P_{nom}	8,2	kW
Minimum heat output (indicative)	P_{min}	2,4	kW

Useful efficiency (NCV as received)

Item	Symbol	Value	Unit
Useful efficiency at nominal heat output	$\eta_{th,nom}$	90,6	%
Useful efficiency at minimum heat output (indicative)	$\eta_{th,min}$	92,8	%

Auxiliary electricity consumption

Item	Symbol	Value	Unit
At nominal heat output	eI _{max}	0,065	kW
At minimum heat output	eI _{min}	0,015	kW
In standby mode	eI _{SB}	0,002	kW

F(4)	0,8%
------	------

Permanent pilot flame power requirement

Item	Symbol	Value	Unit
Pilot flame power requirement (if applicable)	P _{pilot}	N.A.	kW

F(5)	0,0%
------	------

Type of heat output/room temperature control (select one)

Item	Value
Single stage heat output, no room temperature control	no
Two or more manual stages, no room temperature control	no
With mechanic thermostat room temperature control	no
With electronic room temperature control	yes
With electronic room temperature control plus day timer	no
With electronic room temperature control plus week timer	no

F(2)	0,0%
------	------

Other control options (multiple selections possible)

Item	Value
Room temperature control, with presence detection	no
Room temperature control, with open window detection	no
With distance control option	no

F(3)	0,0%
------	------

Contact details

Contact details	JOLLY-MEC CAMINETTI SPA Via San Giuseppe 2, Telgate (BG), 24060, IT info@jolly-mec.it - +39 0358359211
-----------------	---

NOTE



Via S.Giuseppe 2 - 24060 Telgate (Bg) Italy
Tel. +39 035.83.59.211 Fax +39 035.83.59.203
www.jolly-mec.it - info@jolly-mec.it